

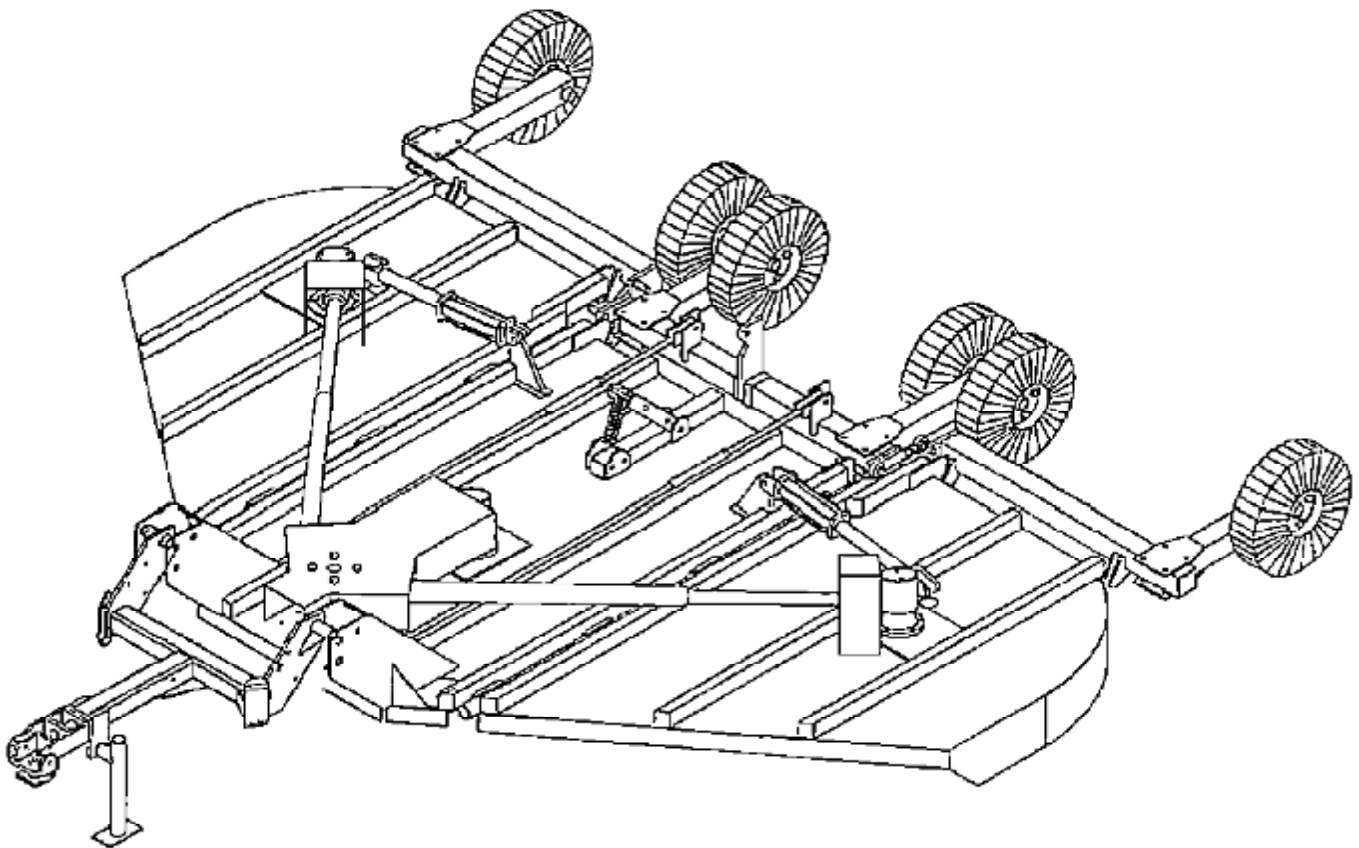

TAYLOR PITTSBURGH, INC.  
P.O. BOX 1200  
WINFIELD, AL 35594  
205-487-3202

# 1510/1550 SERIES FLEX WING ROTARY CUTTER



**OWNER'S MANUAL**

Form Number 1510/1550-09  
May 2023

**TO THE DEALER:**

The cutter assembly and proper installation to the tractor is the responsibility of the TAYLOR PITTSBURGH dealer. Read manual instructions and safety rules. Make sure all items on the Pre-delivery and Delivery Checklists are completed before releasing equipment to the owner.

**TO THE OWNER:**

Read this manual before operating your TAYLOR PITTSBURGH cutter. The information presented will prepare you to do a better and safer job. Keep this manual handy for ready reference. Require all operators to read this manual carefully and become acquainted with all the adjustment and operating procedures before attempting to operate. Replacement manuals can be obtained from your dealer or by calling 1-205-487-3202, in the USA and Canada only.

The cutter you have purchased has been carefully engineered and manufactured to provide dependable and satisfactory use. Like all mechanical products, it will require cleaning and upkeep. Lubricate the unit as specified. Observe all safety information in this manual and safety decals on the cutter and tractor.

For service your authorized TAYLOR dealer has trained mechanics, genuine TAYLOR PITTSBURGH service parts, and the necessary tools and equipment to handle all your needs.

Provide your model number and serial number to your dealer to obtain correct repair parts.

# TABLE OF CONTENTS

INTRODUCTION.....	1
SAFETY SYMBOLS & SIGNAL WORDS.....	3
GENERAL INFORMATION.....	4
BOLT TORQUE CHART.....	4
SPECIFICATIONS .....	5
SAFETY RULES.....	6 - 8
SAFETY DECALS & LOCATION.....	9 - 10
ASSEMBLY.....	11 -15
OPERATION.....	16
ATTACHING .....	17
TRANSPORTING .....	18
ADJUSTMENTS.....	18
MAINTENANCE .....	19
LUBRICATION .....	20
STORAGE .....	20
REPAIR PARTS LISTS.....	21-48
WARRANTY.....	49-51

## SAFETY RULES



**ATTENTION! BECOME ALERT! YOUR SAFETY IS INVOLVED!**



### SAFETY ALERT SYMBOL

**FIG. 1:** This is the safety alert symbol. It means **ATTENTION: BECOME ALERT! YOUR SAFETY IS INVOLVED!** Look for it, both in this manual and on safety decals on the equipment. It will direct your attention to information that involves your safety and the safety of others.



Figure 1

### SIGNAL WORDS

**FIG. 2:** The words **DANGER**, **WARNING** or **CAUTION** are used with the safety alert symbol. Learn to recognize these safety alerts, and follow the recommended precautions and safe practices.

 **DANGER:** The safety alert symbol, with the word **DANGER**, indicates an imminently hazardous situation that, if not avoided, will cause **DEATH OR VERY SERIOUS INJURY**.

 **WARNING:** The safety alert symbol, with the word **WARNING**, indicates a potentially hazardous situation that, if not avoided, could cause **DEATH OR SERIOUS INJURY**.

 **CAUTION:** The safety alert symbol, with the word **CAUTION**, indicates a potentially hazardous situation that, if not avoided, may cause a **MINOR INJURY**.



Figure 2

Replace any **DANGER**, **WARNING**, **CAUTION** or instructional decal that is not readable or is missing. The location and part number of these decals is identified later in the section of the manual.

**IMPORTANT:** The word **IMPORTANT** is used to identify special instructions or procedures which, if not strictly observed could result in damage to, or destruction of the machine, process or its surroundings.

# GENERAL INFORMATION

## INTRODUCTION

**READ THIS MANUAL** carefully to learn how to operate and service your cutter correctly. Failure to do so could result in personal injury or equipment damage.

Throughout this manual, references are made to right and left direction. **RIGHT - HAND AND LEFT - HAND** sides are determined by standing behind the cutter facing the direction the cutter will travel when going forward.

The purpose of this manual is to assist you in operating and maintaining your Series 1500 Flex Wing Cutter. Read it carefully. It furnishes information and instructions that will help you achieve years of dependable performance. These instructions have been compiled from extensive field experience and engineering data. Some information may be general in nature due to unknown and varying operating conditions.

However, through experience and these instructions, you should be able to develop procedures suitable to your particular situation.

Maintain your implement with original repair parts to insure safety and optimum performance.

## WARNING

- Some illustrations in this manual show the cutter with safety components removed to provide a better view. The cutter should never be operated with any safety components removed.

The illustrations and data used in this manual were current at the time of printing, but due to possible production changes, your cutter may vary slightly in detail. We reserve the right to redesign and change the machines as may be necessary without notification.

## BOLT TORQUE CHART

GRADE 2



GRADE 5



GRADE 8

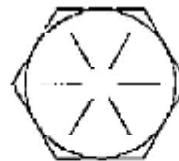

TORQUE IN FOOT POUNDS

BOLT HEADS		3/8	1/2	5/8	3/4	7/8	1
HEX HEAD		9/16	3/4	15/16	1-1/8	1-5/16	1-1/2
UNC GRADE	2	18	45	89	160	252	320
	5	30	68	140	240	360	544
	8	40	100	196	340	528	792

## SPECIFICATIONS

<b>Model</b>	<b>1550</b>	<b>1510</b>
<b>Cutter Size</b>	<b>15'</b>	<b>15'</b>
<b>Cutting Height Range</b>	<b>1 to 15"</b>	<b>1 to 15"</b>
<b>Cutting Width</b>	<b>180"</b>	<b>180"</b>
<b>Overall Width</b>	<b>186"</b>	<b>186"</b>
<b>Transport Width</b>	<b>110"</b>	<b>110"</b>
<b>Overall Length</b>	<b>183"</b>	<b>183"</b>
<b>Gearbox Rating (HP)</b>	<b>Main</b>	<b>125</b>
	<b>Wing</b>	<b>100</b>
		<b>175</b>
		<b>140</b>
<b>Tractor PTO RPM</b>	<b>540</b>	<b>1000</b>
<b>Tractor HP</b>	<b>50 - 100</b>	<b>60 - 150</b>
<b>Input Driveline Size</b>	<b>Cat 6</b>	<b>Cat 4</b>
<b>Wing Driveline Size</b>	<b>Cat 4</b>	<b>Cat 4</b>
<b>Driveline Protection</b>	<b>Slip Clutch</b>	<b>Slip Clutch</b>
<b>Number of Blades</b>	<b>6</b>	<b>6</b>
<b>Blade Size</b>	<b>1/2 x 4"</b>	<b>1/2 x 4"</b>
<b>Blade Overlap</b>	<b>5-1/4"</b>	<b>5-1/4"</b>
<b>Blade Tip Speed (FPM)</b>	<b>Wing</b>	<b>14,850</b>
	<b>Center</b>	<b>14,775</b>
		<b>15,865</b>
		<b>15,415</b>
<b>Brush Diameter Cut</b>	<b>Up to 2"</b>	<b>Up to 2"</b>
<b>Center Frame Thickness</b>		
	<b>Deck</b>	<b>7 gauge</b>
	<b>Sideframe</b>	<b>1/4"</b>
		<b>7 gauge</b>
		<b>1/4"</b>
<b>Side Frame Depth</b>	<b>10"</b>	<b>10"</b>
<b>Tailwheel (Select)</b>	<b>Laminated Pneumatic Aircraft</b>	<b>Laminated Pneumatic Aircraft</b>
<b>Weight w/o Shields (lbs)</b>	<b>4,400</b>	<b>4,400</b>

# SAFETY RULES



**ATTENTION! BECOME ALERT! YOUR SAFETY IS INVOLVED!**



Your personal safety is a primary concern in the design and manufacture of our products. Unfortunately, our efforts to provide safe equipment can be wiped out by a single careless act of an operator.

In addition to the design and configuration of equipment, hazard control and accident prevention are dependent upon the awareness, concern, prudence and proper training of personnel involved in the operation, transport, maintenance and storage of equipment.

It has been said "The best safety device is an informed, careful operator." We ask you to be that kind of an operator.

The design of this equipment depends on it being operated within the limitations as explained in this manual.

## TRAINING

- **Safety instructions are important! Read this manual and the tractor manual; follow all safety rules and safety decal information.** (Replacement manuals are available from dealer or call 1-800-228-2308.) Failure to follow instructions or safety rules can result in serious injury or death.
- **If you do not understand any part of this manual and need assistance, see your dealer.**
- **Know your controls and how to stop engine and cutter quickly in an emergency.**
- **Operators must be instructed in and be capable of the safe operation of the equipment, its attachments and all controls. Do not allow anyone to operate this equipment without proper instructions.**
- **Do not allow children or untrained persons to operate equipment.**

## PREPARATION

- **Always wear close fitting clothing and personal protection equipment called for by the job conditions. These items may include a hard hat, safety glasses, goggles or face shield, hearing protection and safety boots. DO NOT wear loose clothing, jewelry or any other items that may be entangled in moving parts. Tie up long hair.**
- **Ensure cutter is properly mounted, adjusted and in good operating condition.**
- **Tighten all bolts, nuts and bolts, and check that all cotter pins are installed securely to ensure equipment is in a safe condition before operating.**
- **Make sure spring-activated locking pin or collar slides freely and is seated firmly in tractor PTO spline groove.**
- **Tractor must be equipped with ROPS or ROPS CAB and seat belt. Keep seat belt securely fastened. Falling off tractor can result in death from being run over or crushed. Keep foldable ROPS systems in "locked up" position at all times.**
- **Remove accumulated debris from this equipment, tractor and engine to avoid fire hazard.**
- **Ensure all safety decals are installed. Replace if damaged. (See Safety Decals section for location.)**
- **Inspect chain/rubber shielding before each use. Replace if damaged.**
- **Ensure shields and guards are properly installed and in good condition. Replace if damaged.**
- **A minimum 20% of a tractor and cutter weight must be on the tractor front wheels with cutter in transport position. Without this weight, tractor could tip over causing personal injury or death. The weight may be attained with front wheel weights, ballast in tires or front tractor weights.**



## SAFETY RULES



**ATTENTION! BECOME ALERT! YOUR SAFETY IS INVOLVED!**

*(Safety Rules continued from previous page)*

- **Inspect and clear area of stones, branches or other hard objects that might be thrown, causing injury or damage.**

### OPERATIONAL SAFETY

- **Keep bystanders away from cutter while it is in operation.**
- **Never direct discharge toward anyone.**
- **Operate only in daylight or good artificial light.**
- **Always comply with all state and local lighting and marking requirements.**
- **Do not allow other people in the area when operating, attaching, removing, assembling, or servicing cutter.**
- **Make certain all movement of cutter components has stopped before opening blade access cover.**
- **No riders are allowed on equipment.**
- **Always sit in tractor seat with seat belt fastened when operating controls or starting engine. Place transmission in park or neutral, engage brake and ensure all other controls are disengaged before starting tractor engine.**
- **Operate tractor PTO at 540 rpm for 1550 cutter, or 1000 rpm on 1510 cutter. Do not exceed.**
- **Do not operate tractor PTO during transport.**
- **Look down and to the rear and make sure area is clear before operating in reverse.**
- **Do not operate on steep slopes.**

- **Do not stop, start or change directions suddenly on slopes.**

- **Use extreme care and reduce ground speed on slopes and rough terrain.**

- **Watch for hidden hazards on the terrain during operation.**

- **Stop tractor and cutter immediately upon striking an obstruction. Turn off engine, remove key, inspect and repair any damage before resuming operation.**

- **When performing any service or maintenance, disengage power to cutter. Lower all raised components to the ground. Operate valve levers to release any hydraulic pressure. Stop engine, set parking brake and remove key before dismounting tractor.**

- **Keep all persons away from operator control area while performing adjustments, service or maintenance.**

### MAINTENANCE SAFETY

- **Before performing any service or maintenance, disconnect driveline from tractor.**

- **Before working underneath, raise cutter to highest position, install transport locks, and block securely. Blocking up prevents harrow dropping from hydraulic leak down, hydraulic system failures, or mechanical component failures.**

- **Keep all persons away from operator control area while performing adjustments, service or maintenance.**

- **Frequently check blades. They should be sharp, free of nicks and cracks and securely fastened.**

- **Do not handle blades with bare hands. Careless or improper handling may result in serious injury.**





## SAFETY RULES



**ATTENTION! BECOME ALERT! YOUR SAFETY IS INVOLVED!**

*(Safety Rules continued from previous page)*

- Your dealer can supply genuine replacement cutter blades. Substitute blades may not meet original equipment specifications.
- Do not climb or walk on cutter frame, or tires.
- Do not stand on or straddle a tongue when unhitching.
- Never operate cutter until hydraulic cylinders and lines are full of oil and free of air. See operating instructions.

### TRANSPORTING SAFETY

- Use a Slow - Moving - Vehicle (SMV) emblem and proper lighting on the tractor when transporting the cutter.
- Do not road the cutter over 20 MPH (30 KPH) on the best surface conditions. Reduce speed when going up or down hills and when approaching ditches or corners. Towing vehicle must weigh more than towed cutter.
- Raise cutter to highest position for transport and install transport locks.

- Check tire pressure and wheel bolts before and during transport.
- Check condition of hitch pins and bolts, tires and hubs before transporting.
- Do not operate tractor PTO during transport.
- Always comply with all state and local lighting and marking requirements.
- Watch low hanging Overhead Power Lines during transport. Avoid contact as this can cause serious injury or death.
- Always use transport locks to hold cutter in raised position and wings folded in and locked.

### STORAGE

- Block equipment securely for storage.
- Keep playing children and bystanders away from storage area.
- Store on a level surface sheltered from the weather.



## SAFETY DECALS



**ATTENTION! BECOME ALERT! YOUR SAFETY IS INVOLVED!**  
**Replace Immediately If Damaged!**

### DECAL LOCATIONS

The following safety decals are located on your cutter. Read them and follow their instructions for your safety. Keep all decals in place and legible. Replace worn or missing decals. Replacement safety decals are available through your dealer. Order by number listed.

 **WARNING**

**TO AVOID SERIOUS INJURY OR DEATH**

- READ OPERATORS MANUAL (AVAILABLE FROM DEALER) AND FOLLOW ALL SAFETY PRECAUTIONS
- KEEP ALL SHIELDS IN PLACE AND IN GOOD CONDITION
- OPERATE MOWER FROM TRACTOR SEAT ONLY
- LOWER MOWER STOP ENGINE REMOVE KEY BEFORE DISMOUNTING TRACTOR

ALLOW NO CHILDREN OR UNTRAINED PERSONS TO OPERATE EQUIPMENT

FAILURE TO OPERATE SAFELY CAN RESULT IN INJURY OR DEATH

On Wing Deck

 **DANGER**

**ROTATING BLADES AND THROWN OBJECTS**

- KEEP AWAY.
- DO NOT OPERATE IN VICINITY OF OTHER PERSONS.
- CLEAR MOWING AREA OF DEBRIS.
- FULL CHAIN OR RUBBER SHEETING MUST BE USED TO COMPLY WITH OSHA AGRICULTURAL STANDARD 1923.57, SAE J227 AND ANSI B71.4 UNLESS IT INTERFERES SUBSTANTIALLY WITH MOWER FUNCTION DURING AGRICULTURAL USE. IF NOT FULLY SHIELDED, STOP OPERATION WHEN ANYONE COMES WITHIN SEVERAL HUNDRED FEET.

BLADES CONTACT OR THROWN OBJECTS CAN CAUSE SERIOUS INJURY OR DEATH

On Wing Deck

 **DANGER**

**PINCH POINT KEEP-CLEAR** 

Near Wing Hinge Points

 **CAUTION**

THIS IMPLEMENT IS DESIGNED TO BE TOWED BY A FARM TILLAGE TRACTOR

**MAX TOWING SPEED 20 MPH**

SECURELY LOCK WINGS BEFORE TOWING  
READ YOUR OPERATORS MANUAL BEFORE USE



On Wing Deck

 **CAUTION**

READ YOUR OWNERS MANUAL  
USE SAFE OPERATING PRACTICES  
MAX. TRANSPORT SPEED 20 MPH

On Wing Deck

**WARNING**

 1. RAISE AND LOWER WINGS ONLY WHEN UNIT IS IN RAISED OR TRANSPORT POSITION. 

2. STAND CLEAR OF UNIT WHEN WINGS ARE BEING RAISED OR LOWERED.

On Wing Deck



## SAFETY DECALS



**ATTENTION! BECOME ALERT! YOUR SAFETY IS INVOLVED!**  
**Replace Immediately If Damaged!**

*(Safety Decals continued from previous page)*

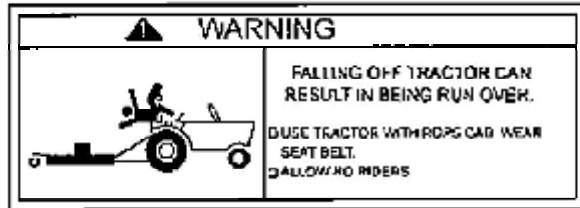

On Left Front Corner of Deck

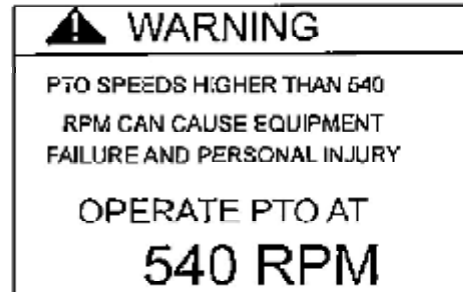

On Front of Deck Near Left Deck Rail



On PTO Driveline Outer Shield & Wing Driveline

OR

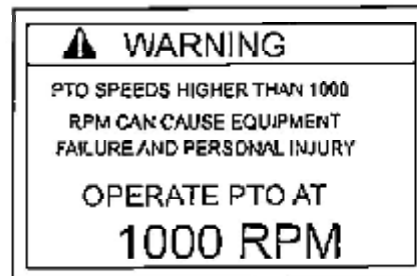

On Front of Deck Near Left Deck Rail.

**Safety Decal Set --- #815998**

# INTRODUCTION & ASSEMBLY INSTRUCTIONS

**Safety** is a primary concern in the design and manufacture of our products. Unfortunately, our efforts to provide safe equipment can be wiped out by a single careless act of an operator.

In addition to the design and configuration of equipment, hazard control and accident prevention are dependent upon the awareness, concern, prudence and proper training of personnel involved in the operation, transport, maintenance and storage of equipment.

It has been said "The **best safety device is an informed, careful operator.**" We ask you to be that kind of an operator.

The operator is responsible for the safe operation of this cutter. The operator must be properly trained. Operators should be familiar with the cutter and tractor and all safety practices before starting operation. Read the safety information on pages 5 through 7.

This cutter is designed for normal farm usage.

Recommended cutting speed for most conditions is from one to six mph.

Maintain your cutter with original repair parts to insure optimum performance.

## MODIFICATIONS

It is the policy of the manufacturer to improve its products whenever possible and practical.

We reserve the right to make changes, improvements, and modifications at any time without incurring the obligation to make such changes, improvements, and modifications on any cutter sold previously.

### **WARNING**

**Do not use bare hand to check for hydraulic leaks. Hydraulic fluid under high pressure can penetrate skin and cause poisoning.**

## ASSEMBLY

### General

Your Series 1510/1550 Flex Wing Rotary Cutter is shipped in bundles for assembly. Remove all wiring from bundles as they are called for. Choose a level area to arrange the parts conveniently. Assemble parts for each step loosely to insure fit. Use flatwashers with slotted holes. Always use lockwashers unless a lock nut is called for. Tighten hardware after parts are installed according to the torque chart given. Unless otherwise stated, all hardware is Grade 5. The following assembly steps are given to minimize the need for adjustment after assembly. Remember that **LEFT and RIGHT** are determined by standing at the rear of the cutter and facing it.

### **WARNING**

The manufacturer strongly recommends installation of deflector shields. A rotary cutter without deflector shields can discharge large objects at high speeds which could seriously injure bystanders or the operator.

### Cutter Deck (Refer to Fig 1)

1) Place the center cutter deck in the middle of the assembly area and block approximately 15" off the ground.

### **WARNING**

Be sure deck is supported on all sides and is stable. Be sure deck is level. **DO NOT** place hands or feet under deck. **DO NOT** crawl under deck for any reason.

2) Align one wing with center deck. Support wing at same height as center deck and be sure wing is stable. Make sure deck is level from left to right.

3) With hinge points aligned end to end, drive hinge rod through hinge points going from front to rear. Secure with collar and cotter pin.

4) Attach remaining wing repeating steps 2 & 3.

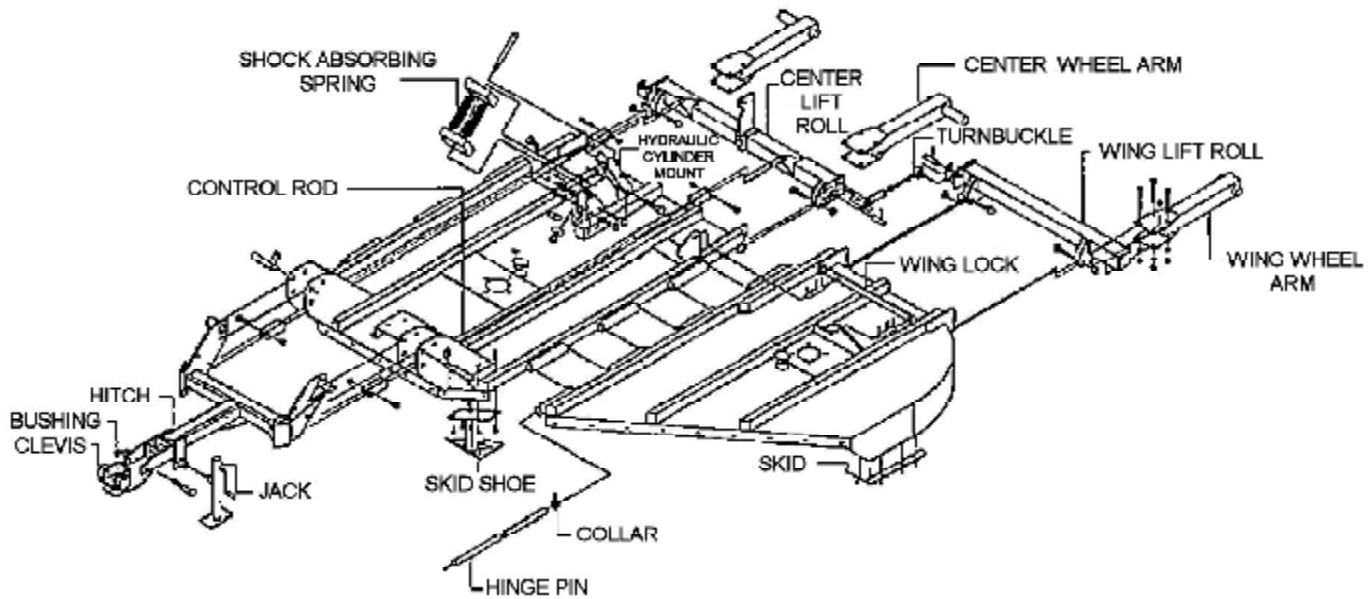

FIGURE 1 - DECK ASSEMBLY

### Wheel Lift Assembly (Refer to Fig 1)

1) Attach center and wing lift rolls to decks using hardened pins and cotter pins provided. Parts must be free to rotate.

2) Assemble wheels axles to wheel arms by aligning hole in spindle tube with hole in wheel spindle. Secure with a 1/2" x 3" bolt and locknut.

3) Attach wheel arms to lift rolls using four 3/4" x 6" bolts per wheel arm. Secure with lockwashers and nuts. Wheel arm width can be adjusted to suit cutting conditions.

**NOTE:** On Dual Wheel models, the center wheel arms have a longer spindle tube. Attach to lift roll with long end of spindle tube to outside.

4) With wheels resting on the ground attach center lift roll to left and right wing lift rolls with turnbuckles. Adjust turnbuckle so wing wheel tube and center center wheel tube are parallel.

Secure with pins and roll pins. (Pins should be inserted so roll pins are toward center of cutter)

### Tongue Assembly (Refer to Fig 1)

1) Attach tongue to the deck using two step pins with click pins. Tongue must be free to rotate.

2) Mount the jack to the tongue and use it to support the tongue for further assembly.

3) Attach female ends of the control rods to the tongue and secure using 3/4" x 3" bolts and locknuts.

4) Attach male ends of the control rods to center lift roll and secure with 3/4" x 3-1/2" bolts and locknuts.

## Center Driveline

The center driveline attaches between the splitter gearbox on the front of the cutter and the center deck gearbox.

- 1) Loosen the bolt on the slipclutch end of the shaft and slide this end onto the center deck gearbox. Tighten bolt to secure in place.
- 2) Depress push button on other end of shaft and slide this end onto the splitter gearbox until push button releases. Slide back and forth to ensure it is locked in place.

## Wing Drivelines

The wing drivelines attach between the splitter gearbox on the front of the cutter and the wing deck gearboxes.

- 1) Loosen the bolt on the slipclutch end of the shaft and slide this end onto the wing deck gearbox. Tighten bolt to secure in place.
- 2) Depress push button on other end of shaft and slide this end onto the splitter gearbox until push button releases. Slide back and forth to insure it is locked in place.
- 3) Attach shield retaining chain included with driveline to shield and control rod. The chain keeps the driveline shield from rotating when the PTO is engaged. Make sure the chain is installed properly at all times to prevent rotation of the shield.

## Driveline Shields (Refer to Fig 2)

**IMPORTANT:** There are three shields that bolt to this cutter to protect the operator from the rotating shafts and slipclutches. Keep these shields in place at all times and in good repair. Replace broken shields or damaged.

- 1) Align holes in splitter shield with holes in splitter gearbox, shield should rest on splitter gearbox and center deck gearbox. Secure with 1/2" flatwashers, lockwashers, and hex nuts.
- 2) Attach wing driveline shields to wing gearboxes using M8 x 16 bolts with 5/16" flatwashers and lockwashers.

## Hydraulic Components

(Refer to Fig 3)

- 1) With hydraulic line ports facing up, attach butt end of 3 x 12 wing cylinder to bracket on center deck using pin and cotter pins provided.
- 2) Remove port plug on rod end of cylinder body to allow movement of piston.
- 3) Pull rod out to align clevis with bracket on wing. Attach rod end of cylinder to bracket using pin and cotter pins provided.
- 4) Attach remaining 3 x 12 cylinder to other wing in similar procedure.
- 5) With hydraulic line ports facing up, attach butt end of 3 x 8 wheel lift cylinder to spring bracket on rear center of center deck using pin and cotter pins provided.
- 6) Remove port plugs on cylinder body to allow movement of piston.
- 7) Extend rod to align clevis with hole in center lift roll cylinder anchor. Attach cylinder clevis to anchor using pin with cotter pins.

## Hydraulic Hose Assembly

Each hose has only one swivel end so it is important to connect the end with the non swivel to cylinder port first. Always tighten each hose end as it is connected before proceeding.

Use a thread sealant on fittings to prevent leaking. DO NOT OVER TIGHTEN.

- 1) Screw a 90°str-el into rod port of wing cylinder. Attach a restrictor fitting into 90° str-el. Attach one hose non swivel end to restrictor fitting of each wing cylinder.
- 2) Attach one hose to butt end of lift cylinder using the end with the non swivel adapter.

**IMPORTANT:** Do not over tighten hoses. Use teflon tape on threads to insure a good seal and prevent leakage.

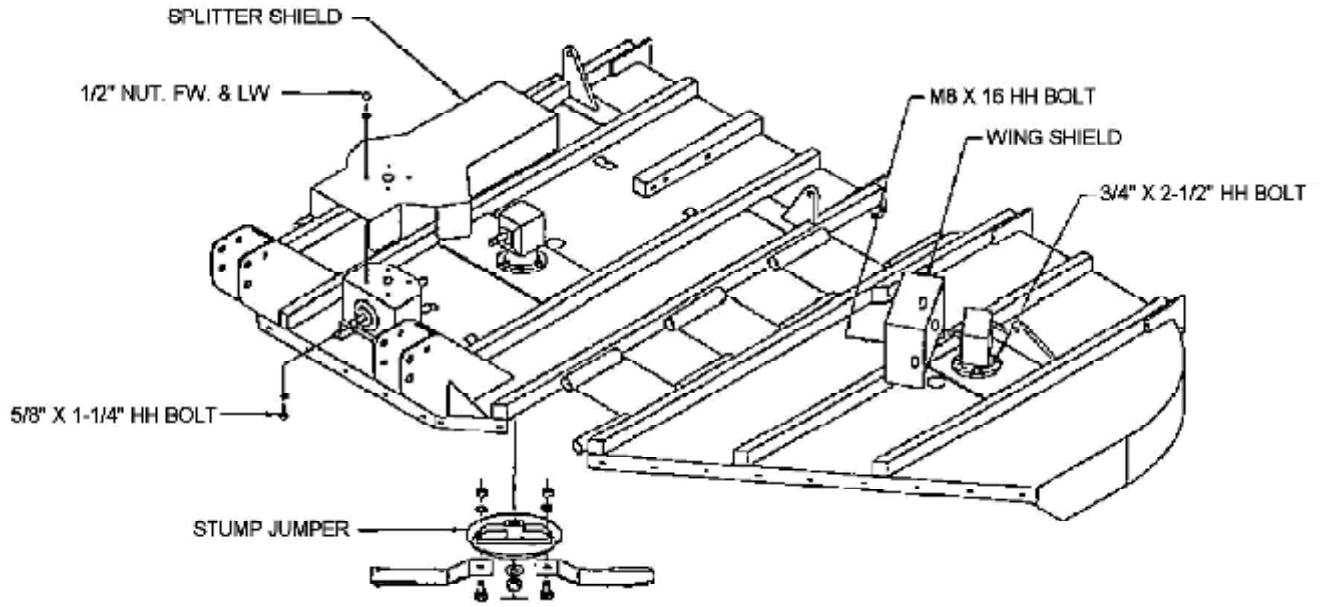

**FIGURE 2 - DRIVELINE SHIELDS**

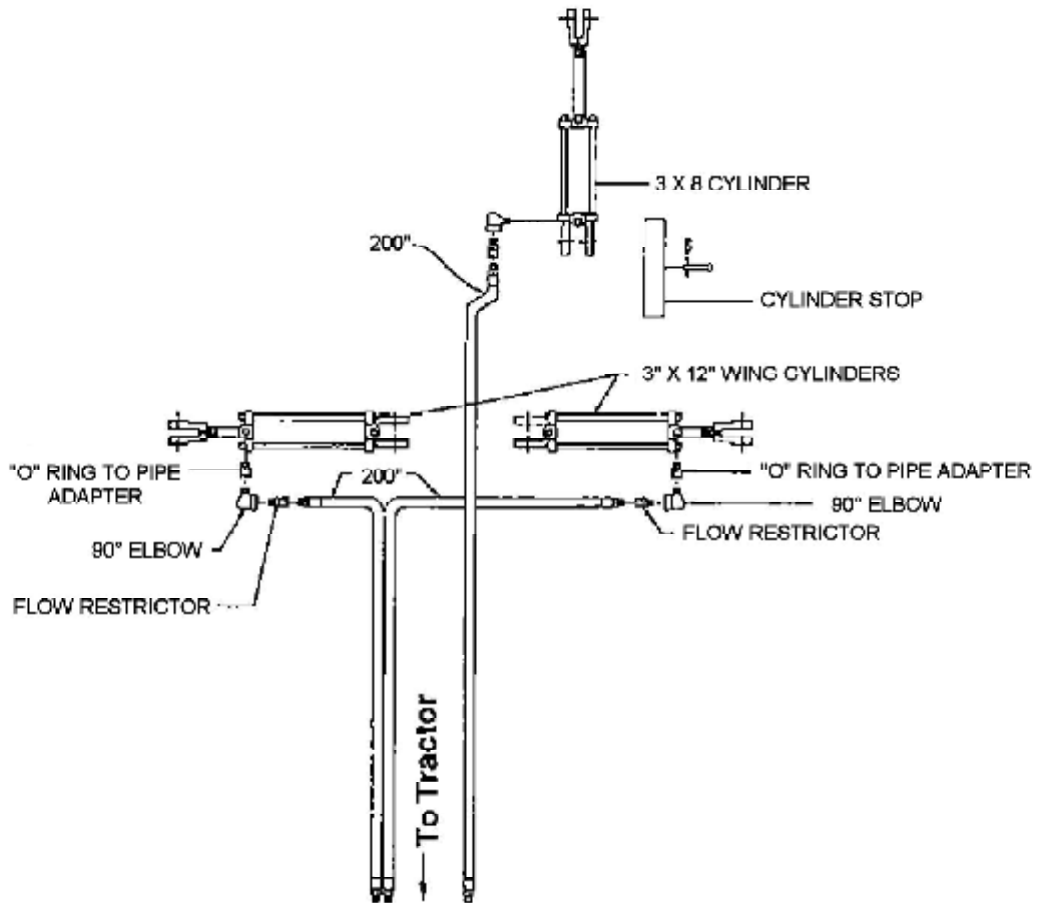

**FIGURE 3 - HYDRAULIC COMPONENTS**

3) Thread hoses through hose clamps mounted on deck. Secure with 1/2" x 1-1/4" carriage bolts with lockwashers and nuts.

4) Attach tractor couplers to other end of hose. (Not provided)

4) Check all fittings to see that they are tight.

### **▲ WARNING**

Do not use bare hand to check for hydraulic leaks. Hydraulic fluid under high pressure can penetrate skin and cause poisoning.

### **Deflector Shields (Refer to Fig. 4)**

Shields are shipped fully assembled and need only be mounted to cutter deck.

1) Arrange shields on ground to be sure of placement on your cutter.

2) Attach shields to your cutter using hardware supplied in the shield bundle.

3) Check and tighten all hardware.

### **▲ WARNING**

When this cutter is operated in populated areas or other areas where thrown objects could injure persons or property, full chain shielding (which is designed to reduce the possibility of thrown objects) must be installed. If this cutter is not equipped with full chain shielding, operation must be stopped when anyone comes within several hundred feet.

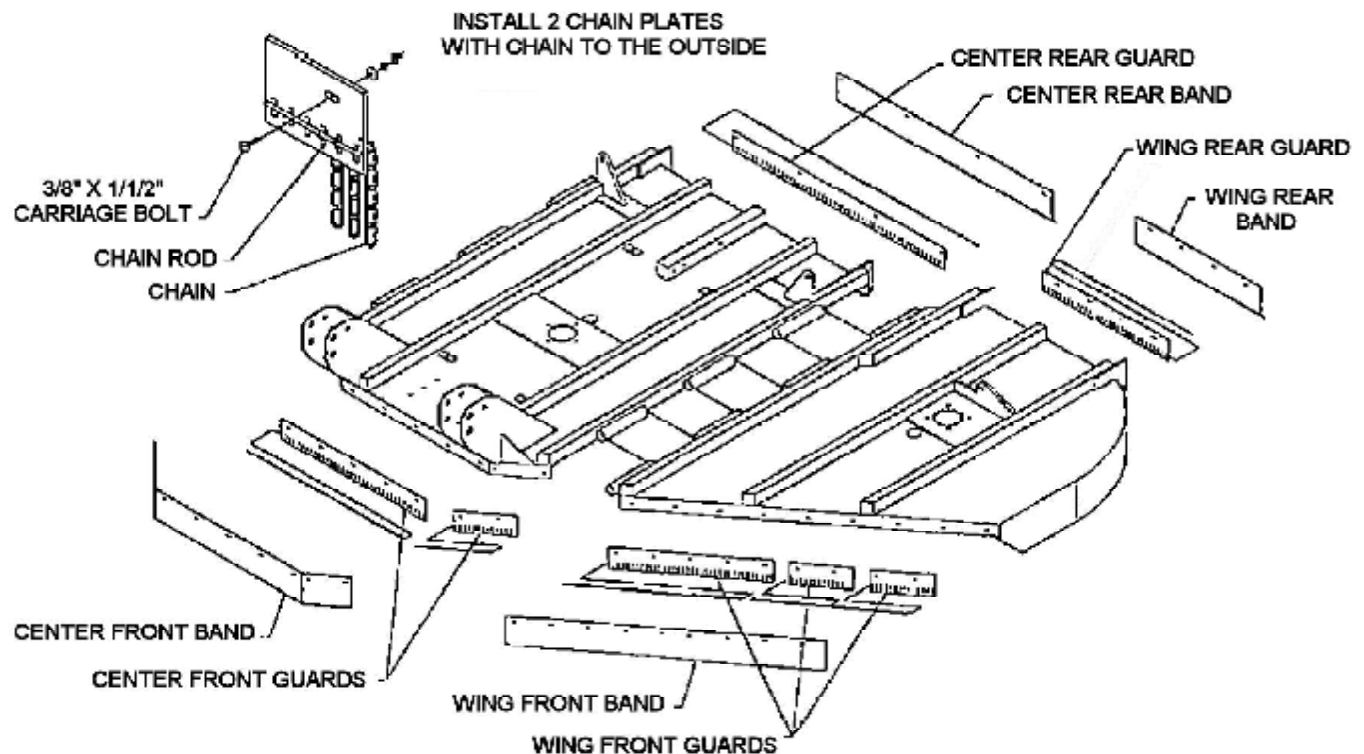

FIGURE 4 - DEFLECTOR SHIELDS



# OPERATION

## BEFORE OPERATION

1) Tighten all loose hardware using the torque chart. **SEE ASSEMBLY.** Replace any missing hardware. On new machines, all hardware must be rechecked after first few hours of operation.

2) Replace any bent or broken parts.

3) Perform lubrication on implement as recommended. **SEE MAINTENANCE.**

4) Refer to your Tractor's Owner's Manual for recommended adjustments and weight distribution.

5) Fill the cutter's gearboxes to proper level using SAE 90EP gear oil. **DO NOT** overfill.

6) Check gearbox mount bolts to see that they are tight.

7) Check all shields and make sure they are in place.

8) Check blades for signs of wear or damage. Sharpen dull blades and replace bent or broken blades. See **BLADE REPLACEMENT.**

9) Inspect hydraulic lines and fittings for wear and leaks. Repair or replace if needed.

### **WARNING**

Check for small high pressure leaks by passing a piece of cardboard or wood over lines rather than hands. High pressure oil can penetrate skin and can only be removed surgically.

10) Read the **SAFETY** section of this manual to be sure of all precautions.

## Preparing the Tractor

- See Recommended Tractors in the Specification section.

- Consult tractor operator's manual for specific adjustment procedures, tire inflation, wheel spacing, and ballast requirement.

- Check hydraulic oil level. Fill, if necessary.

- Turn metering valves to fast position.

- If tractor is equipped with a 3-point quick coupler, raise 3-point hitch fully. Be sure rockshaft lever is set to keep quick-coupler up at all times.

- If not equipped with a 3-point quick coupler, secure lift links and top link so they do not swing into tractor tires, hitch, or onto hydraulic hoses.

- Place tractor drawbar in fixed centered down position, 16 to 20 inches from ground to top of drawbar.

- Adjust drawbar hole 14" from end of pto shaft for 540 rpm and 16" from end of PTO shaft for 1000 RPM cutter.

- Always use a safety hitch pin of the correct diameter. Make sure the hitch pin is locked in place with a safety type lock pin or other locking device.

## Attaching Tractor to Cutter

### WARNING

Be sure bystanders are clear. Do not stand between cutter and tractor. Shut off tractor and engage parking brake prior to dismounting.

- 1) Back tractor to align drawbar with clevis.
- 2) Attach hitch to drawbar with a high strength drawbar pin and secure with a clip pin.
- 3) Attach driveline to tractor. Make sure driveline locks in place.
- 4) Attach driveline shield retaining chain to drawbar to prevent rotation during operation.
- 3) Attach hydraulic hoses to your tractor couplers.
- 4) Crank jack up and remove pin. Store on wing deck lug.

## OPERATION

### First Time Out

- 1) Start tractor engine to perform hydraulic system check.
- 2) Extend wheel lift cylinder to lift cutter from supports.
- 2) Watch fittings for leaks. If leaks are noticed, shut off tractor, relieve pressure from hydraulic lines, and make repairs before proceeding.
- 4) Remove supports and extend and retract wheel lift cylinder through full range of movement a number of times to purge it of air. Check for any interference.
- 5) Remove wing locks from cylinder pins on center deck.

### WARNING

DO NOT raise wings without flow restrictors. Wings will fall rapidly while lowering, and could cause serious injury or death.

### WARNING

Be sure bystanders are clear before lifting wings. Do not walk under raised wings for any reason. Do not stand between implement and tractor. Hydraulic or mechanical failure can allow wings to drop suddenly and unexpectedly.

Perform all tractor operations only while seated in the tractor seat. Do not stand beside tractor.

- 6) Lift wings one at a time and then lower to operating position one at a time. Check for any interference.
- 7) Repeat cycle several times to remove air from system. Finally, set wings in operating position.
- 8) By filling the hydraulic circuitry of cutter with fluid, the tractor's hydraulic fluid reservoir is depleted of fluid. Check fluid level and refill as necessary.

### WARNING

Do not perform any maintenance on tractor with engine running. See the tractor's Operator's Manual

### WARNING

Before working underneath, raise cutter to highest position, install transport locks, and block securely. Blocking up prevents cutter dropping from hydraulic leak down, hydraulic system failures, or mechanical component failures.

## Adjustments

1) Check front to rear level of cutter. The rear should be about 1" higher than the front. This allows the blades to rotate above material previously cut. This in turn prevents double cutting. The result is less power consumed which reduces tractor fuel consumption and wear on cutter drive components.

a) Adjustment is made by varying the length of the control rods. Remove tension from control rods, then remove male end of control rods from lift roll and adjust in or out until proper adjustment is achieved. Level by extending or retracting lift cylinder.

2) Wing adjustment is made with cutter on a hard flat surface and wing cylinders extended. Check to see that all decks are level from left to right. If a wing is tilted down, its lift roll linkage must be lengthened. If a wing is tilted up, its lift roll linkage must be shortened.

Follow the procedure outlined to make adjustments:

a) Lower cutter until center deck skids are 1--2 inches (25.4 - 50.8 mm) off the ground.

b) Relieve any pressure from lift roll linkage by extending or retracting wing cylinder.

c) Disconnect linkage at one end.

d) Level wing by extending or retracting wing cylinder.

e) Adjust and reconnect linkage.

## Operating

1) Start tractor. Raise cutter to remove lift cylinder stop.

2) Adjust cutter to desired cutting height.

3) Remove wing locks from center deck and lower wings to operating position.

4) Engage PTO at idle speed.

5) Slowly adjust engine speed to operating RPM (540 or 1000). Gearboxes on a new cutter may be noisy. This is normal and should subside after break-in period.

6) For maximum efficiency, operate at a ground speed which allows cutting at desired height without bogging down cutter.

## WARNING

All cutters are capable of discharging large objects from beneath deck. Therefore, do not operate around bystanders or passers-by. Do not operate near highways without shields, bands or other ASAE approved cutter shields in place and in good repair.

## TRANSPORTING

1) Disengage PTO and allow all moving parts to completely stop.

2) Raise cutter and install lift cylinder stop.

3) Raise wings and install wing locks.

## WARNING

When implement is transported on public roads day or night, use signal lights conforming to local law. A Slow Moving Vehicle (SMV) emblem must be displayed and be visible from the rear. Do not exceed 20mph travel speed.

4) Transport at no more than 20 MPH. Use caution on rough terrain.

5) Check local laws governing transport of farm equipment on public roads.

6) Use caution and be aware of oncoming traffic and roadside obstructions.

7) Always use a slow moving vehicle (SMV) emblem. Mount it to the bracket on the rear wheel lift cylinder bracket.

8) **DO NOT** transport on public roads at night.

9) **BEWARE** of overhead wires and **KNOW** the transport height and width of your cutter. Avoid contact as this can cause serious injury or death. See Specification Section.

## Removing Cutter from Tractor

- Select a level well drained area to park cutter.
- Stop engine, set parking brake, and remove key before dismounting tractor.
- Install wheel chocks on cutter.

### **WARNING**

To help avoid injury from escaping hydraulic fluid under pressure, relieve the pressure in the system by shutting off tractor and moving remote cylinder operating levers in both directions before attaching to or detaching from the breakaway couplers.

- Remove hydraulic pressure from lines and disconnect hydraulic quick couplers.
- Install parking jack on tongue and raise tongue to remove pressure from tractor drawbar.
- Do not stand on or straddle a tongue when unhitching.
- Remove input driveline from tractor.
- Disconnect cutter from tractor and carefully drive tractor away from cutter.

## MAINTENANCE

### Gearbox

- 1) Check oil level in gearbox about every 8 hours of use. Fill to side port using only SAE 90EP gear oil.
- 2) Check mounting bolts before each use to be sure they are tight.

## Blade Inspection and Replacement

Inspect blades before each use. Sharpen worn blades and replace in pairs if blades are damaged.

To replace blades, follow the steps below:

- 1) **Support cutter from below on all sides. DO NOT** rely on tractor's hydraulic lift alone to support cutter. Be sure cutter is stable before proceeding.
- 2) Remove each blade bolt nut and lockwasher through the access holes in the decks.
- 3) Using a punch, drive the blade bolt out of the blade holder.
- 4) Insert blade bolts in new blades so that flare in blade tip is up. Insert bolt with blade onto blade holder by aligning notch in hole with protrusion on bolt.
- 5) Replace lockwashers and nuts on bolts and tighten.

## Wheel Hubs

After initial use check wheel hubs for excessive play on spindle. If necessary tighten bearing adjustment nut to eliminate lateral movement on spindle while still allowing hub rotation.

## Slip Clutch

### Operational Check:

On a new unit or one that has been stored between seasons, perform the following check:

- 1) Loosen all spring retaining nuts until springs can be turned with fingers.
- 2) With tractor at idle speed, engage PTO for 2--3 seconds. Clutch should slip without turning blades. If not, contact your dealer.
- 3) Retighten nuts to compress springs according to diagram. Dim "A" is 1-9/32" for Corner clutches and 1-3/32" for Bondioli.

## **⚠ WARNING**

Failure to retighten nuts can cause damage to implement and/or tractor due to improper slip clutch torque setting.

### **Adjustment:**

The slip clutch is designed to slip when blades encounter heavy brush or solid permanent objects. If this is not occurring or clutch slips too much (i.e. smoke appears around clutch), adjustment should be made as follows:

- 1) Check to be sure that all springs are compressed to the correct length. Adjust spring length by tightening or loosening retaining nut.
- 2) If clutch still performs improperly, tighten or loosen all nuts in 1/32" increments until clutch performs properly.
- 3) If excessive adjustment is necessary, consult your dealer.

### **Lubrication Schedule**

Clean grease fittings before applying grease. Use multipurpose, lithium base grease.

### **Before Each Use**

Tail Wheels -- Apply grease at hub fitting.

Driveline -- Apply grease to universal joints and shield fittings.

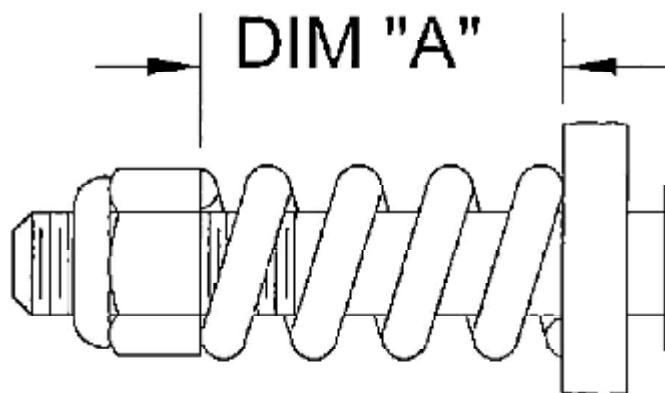

SLIP CLUTCH SPRING

### **Every 8 Hours**

Driveline -- Apply grease to universal joints and shield fittings.

CV Drive -- Grease CV center mechanism 30 pumps initially and 10 pumps every 8 hours.

### **Every 16 Hours**

Driveline -- Lubricate push buttons with oil.

Driveline -- Disconnect driveline and separate sections. Apply a thin coat of grease to outside of male shaft. Reassemble driveline and install. Be sure driveline is locked in place and shield retaining chain is properly attached.

Wheel Bearings -- Apply grease slowly with grease gun until grease relieves around seal.

Gearboxes -- Use SAE90EP Gear oil if needed.

### **STORAGE**

1) Clean all debris from cutter deck and driveline.

2) Store cutter on a level surface sheltered from the weather.

3) Lower equipment to the ground and block to prevent rolling.

4) Store cutter supported on blocks to allow air circulation beneath cutter.

5) Keep playing children and bystanders away from storage area.

### **BLADE ROTATION VIEWED FROM TOP DOWN**

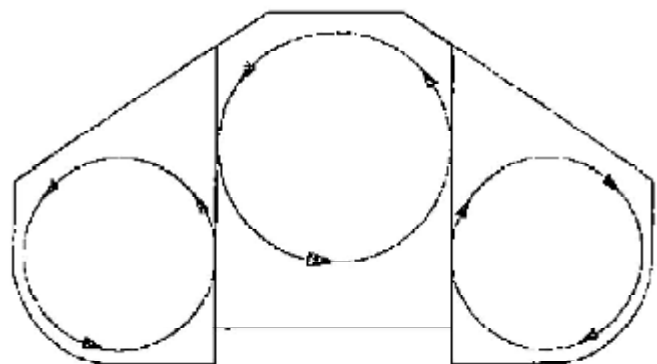

BLADE ROTATION DECAL

**EXPLODED ASSEMBLY  
AND REPAIR PARTS  
SECTION**

# DECKS & WHEEL CARRIAGE COMPONENTS

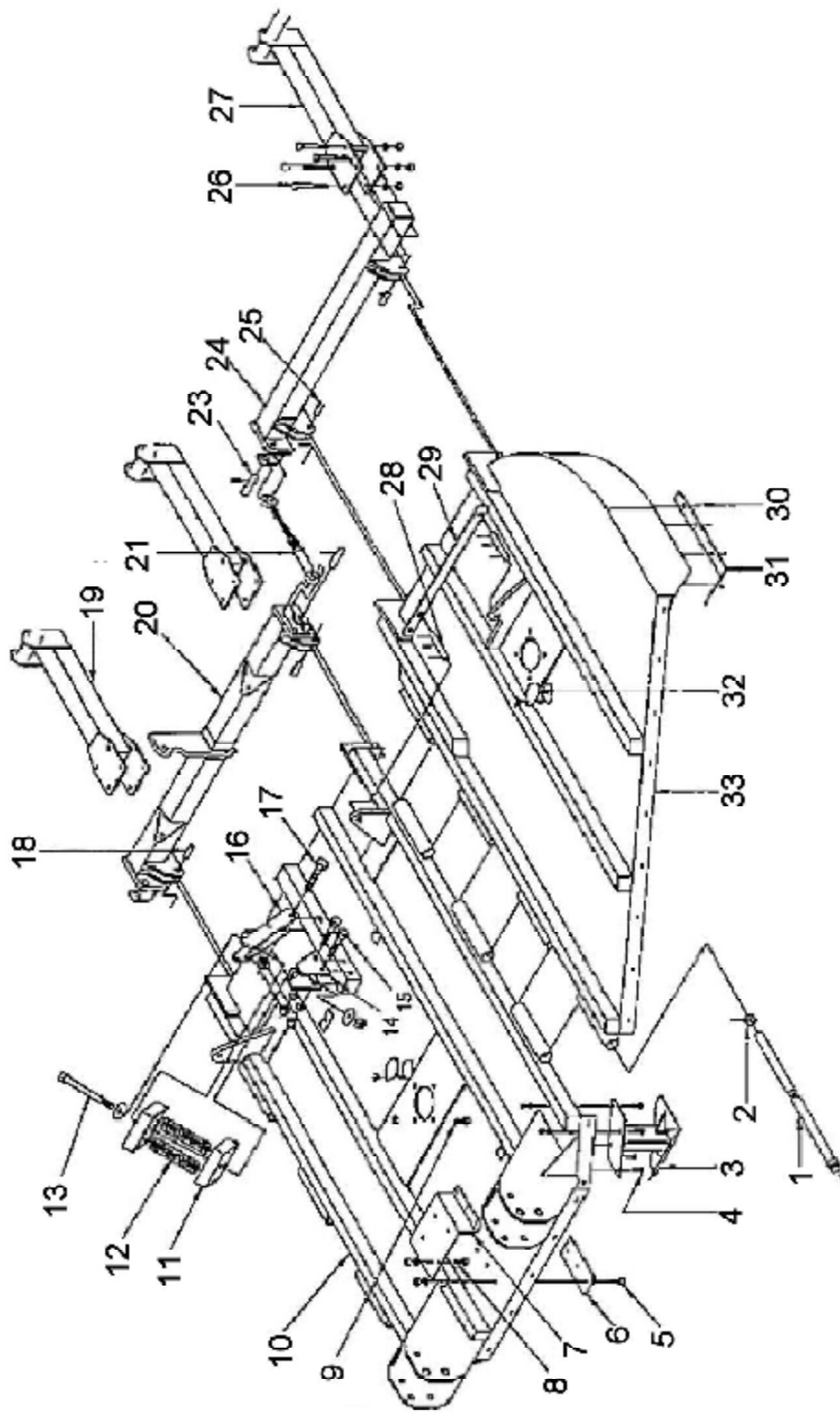

FIGURE 6 – DECKS & WHEEL CARRIAGE COMPONENTS

**DECKS & WHEEL CARRIAGE COMPONENTS (Refer to Figure 6)**

<b>Item</b>	<b>Part No.</b>	<b>Description</b>	<b>Qty.</b>
1	811582	HINGE TUBE ---WAS #809356 PRIOR TO 1-26-01	2
2	811584	COLLAR---WAS #809358 PRIOR TO 1-26-01	2
	304142	PIN/COTTER 5/16 x 3	2
3*	812140	LEFT CENTER FRAME SKID SHOE	1
	812141	RIGHT CENTER FRAME SKID SHOE	1
4	303651	HHCS 1/2 x 1-1/2 GR5	8
	303985	WASHER/FLAT 1/2	8
	303955	WASHER/LOCK 1/2	8
	304007	NUT/HEX 1/2 NC	8
5	303651	HHCS 1/2 x 1-1/2 GR5	6
	303955	WASHER/LOCK 1/2	6
	304007	NUT/HEX 1/2 NC	9
6	810351	REINFORCEMENT/DECK	2
7	810433	SPLITTER GEARBOX PLATE	1
8	303676	HHCS 5/8 x 2 GR5	4
	303956	WASHER/LOCK 5/8	4
	304008	NUT/HEX 5/8 NC	4
9	303701	HHCS 3/4 x 2-1/2 GR5	4
	304074	NUT/HEX FLANGE LOCK 3/4	4
10	812139	CENTER DECK/ 15 FT	1
11	812230	SPRING PAD	2
12	206612	SPRING/COMPRESSION	2
13	812241	SPRING ROD	1
	304011	WASHER/FLAT - 1	2
	304024	NUT/HEX LOCK - 1	1
14	810703	SPRING ANCHOR	1
15	303707	HHCS 3/4 x 5 GR5	2
	303957	WASHER/LOCK 3/4	2
	304009	NUT/HEX 3/4 NC	2
16	810706	CYLINDER MOUNT	1
17	303762	HHCS 1 x 5-1/2 GR5	1
	304024	NUT/HEX LOCK - 1	1

Continued on following page

**NOTE: LEFT & RIGHT are determined by standing at rear of cutter and facing it.**



## DECKS & WHEEL CARRIAGE COMPONENTS (Refer to Figure 6)

<b>ITEM</b>	<b>PART NO.</b>	<b>DESCRIPTION</b>	<b>QTY.</b>
18	810013	PIN/AXLE PIVOT 1" DIA.	2
	304124	PIN/COTTER 1/4" X 2"	4
19	609381	WHEEL ARM LAM. & AIRCRAFT DUAL	2
	813541/R & 813642/L	WHEEL ARM DUAL PNEUMATIC	2
	809382	WHEEL ARM SINGLE LAMINATED & AIRCRAFT	2
	813540	WHEEL ARM SINGLE PNEUMATIC	2
20	812144	CENTER TAILWHEEL TUBE ASSY	1
21	404940	TURNBUCKLE 1510/1550 CUTTER	2
23	811394	PIN/WHEEL TUBE	4
	304264	PIN/ROLL 7/16" X 2"	4
24*	812032	RIGHT WING TAILWHEEL TUBE ASSY	1
	812033	LEFT WING TAILWHEEL TUBE ASSY	1
25	810013	PIN/AXLE PIVOT 1" DIA.	4
	304124	PIN/COTTER 1/4" X 2"	8
26	303709	HHCS 3/4" X 5 GR5	16
	303757	WASHER/LOCK 3/4"	16
	304009	NUT/HEX 3/4" NC	16
27	809382	WING WHEEL ARM LAMINATED & AIRCRAFT	2
	813540	WING WHEEL ARM PNEUMATIC	2
28	809444	PIN/WING CYL & LOCK	4
	304111	PIN/COTTER 3/16" X 2"	12
29	809446	WING LOCK BAR	2
30	303911	FLT C'SUNK 1/2" X 1-1/4" GR5	6
	303791	WASHER/FLAT 1/2"	6
	303955	WASHER/LOCK 1/2"	6
	304007	NUT/HEX 1/2" NC	6
31	608203	SKID PLATE	2
32	811650	ACCESS HOLE COVER	3
33*	304214	NUT/WING 3/8"	3
	812084	LEFT WING DECK 15 FT	1
	812085	RIGHT WING DECK 15 FT	1

NOTE: LEFT & RIGHT are determined by standing at rear of cutter and facing it.

# HITCH & LEVELING COMPONENTS

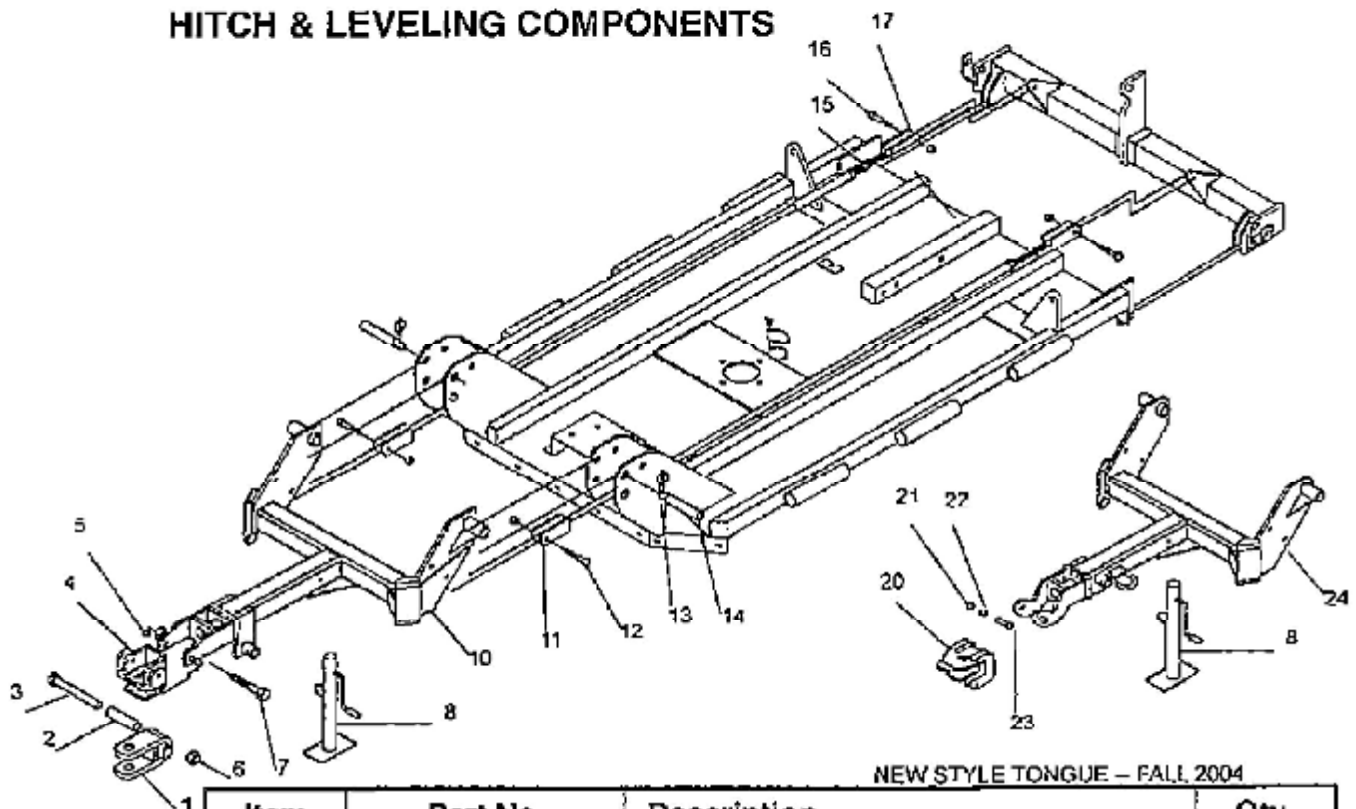

NEW STYLE TONGUE - FALL, 2004

Item	Part No.	Description	Qty.
1	211033	CLEVIS ASSY	--
2	813973	BUSH/PIVOT 1-3/8 OD x 5-1/16" LONG	--
3	303767	HHCS 1 x 8" GR5	--
	813972	KIT/CLEVIS INCLUDES 1,2,3, & 6	--
4	813746	CLEVIS ASSY	1
5	24359	BUSH/PIVOT 1.0 DIA X .78 ID X .88	2
6	304024	NUT/HEX LOCK 1" NC	--
	303703	HHCS 3/4" x 3" GR5	2
7	304022	NUT/HEX LOCK 3/4" NC	2
8	808009	JACK/5,000# SIDE WIND	1
10	813732	TONGUE ASSY	1
	811959	ATTITUDE ROD/FEMALE 101-1/4"	2
11	608512	ATTITUDE ROD/FEMALE 98-3/4" (Used with #608501 Tongue)	2
	303703	HHCS 3/4" x 3" GR5	2
12	304022	NUT/HEX LOCK 3/4" NC	2
13	303113	PIN/CLICK	2
14	042138	PIN/HITCH 1-7/16 DIA. X 8-7/8 CAT III	2
15	304011	NUT/HEX 1" NC	2
	303704	HHCS 3/4" x 3-1/2" GR5	2
16	304022	NUT/HEX LOCK 3/4" NC	2
17	810692	SWIVEL ASSY 14.62"	2
20	608507	CLEVIS ASSY/DUCKBILL - 15 FT	1
21	304022	NUT/HEX LOCK 3/4" NC	2
22	24359	SLEEVE/1" OD X 3/4" ID X 7/8"	2
23	303701	HHCS 3/4 X 2-1/2" GR5	2
24	608501	TONGUE ASSY - 15 FT	1

## GEARBOX SHIELDS & STUMP JUMPER COMPONENTS

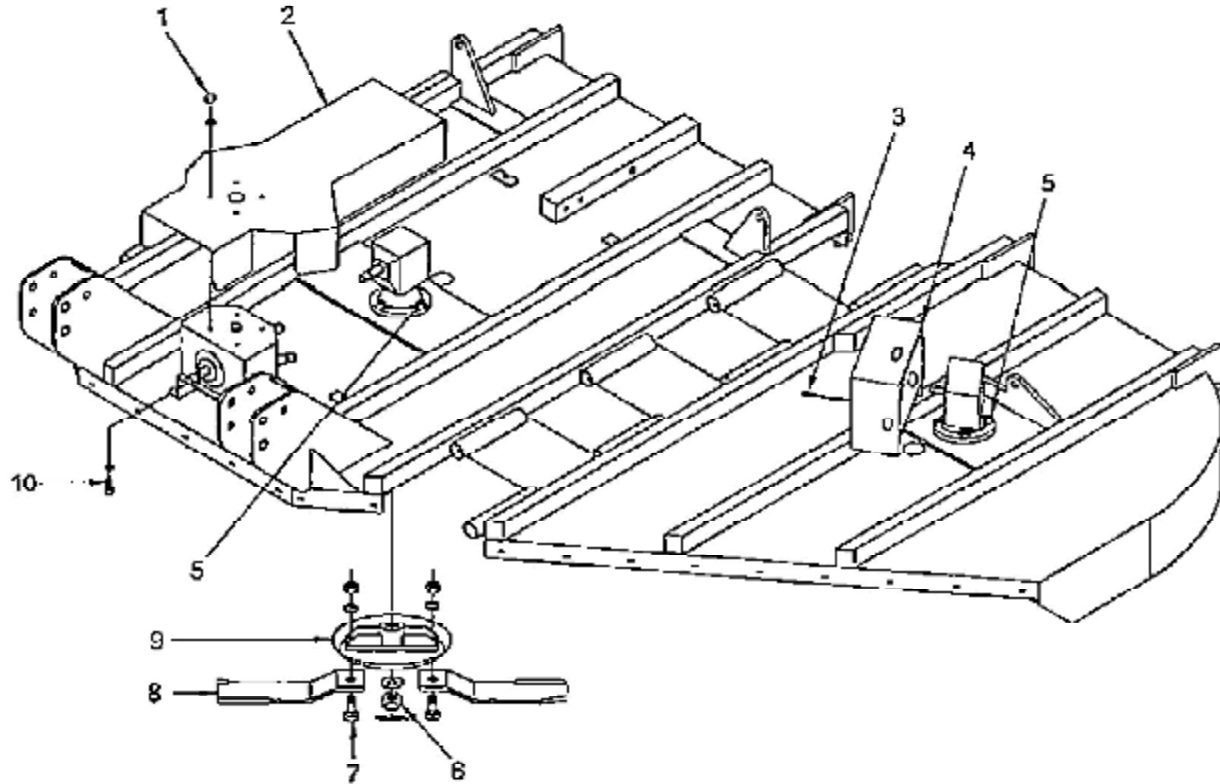

Item	Part No.	Description	Qty.
1	303971	WASHER/FLAT 1/2"	4
	304007	NUT/HEX 1/2" NC	4
	303955	WASHER/LOCK 1/2"	4
2	812165	SHIELD/SPLITTER	1
3	807026	HHCS M8 X 16 8.8	4
	303968	WASHER/FLAT 5/16	4
4	303952	WASHER/LOCK 5/16	4
	812206	SHIELD/WING GEARBOX	2
5	303701	HHCS 3/4" x 2-1/2" GR5	12
	304074	NUT/HEX FLANGE LOCK 3/4"	12
6	608348	NUT/CASTLE M 30 x 2	3
	810871	WASHER/FLAT	3
	505310	PIN/COTTER 5/32 x 1-1/4	3
7	50573901	BOLT/BLADE BB55	6
	303960	WASHER/LOCK 1-1/8"	6
	304765	NUT/CASTLE 1-1/8" NF GR8	6
8*	809459	BLADE/CENTER SPINDLE 1/2" X 4" X 30.25" CCW	2
	809460	BLADE/RIGHT SPINDLE 1/2" X 4" X 24.25" CW	2
	809461	BLADE/LEFT SPINDLE 1/2" X 4" X 24.25" CCW	2
9	608200	STUMP JUMPER	3
10	303676	HHCS 5/8 x 2 GR5	4
	303956	WASHER/LOCK 5/8	4
	304008	NUT/HEX 5/8 NC	4

\*NOTE: LEFT & RIGHT are determined by standing at the rear of the cutter and facing it.

## CHAIN & BAND SHIELDING

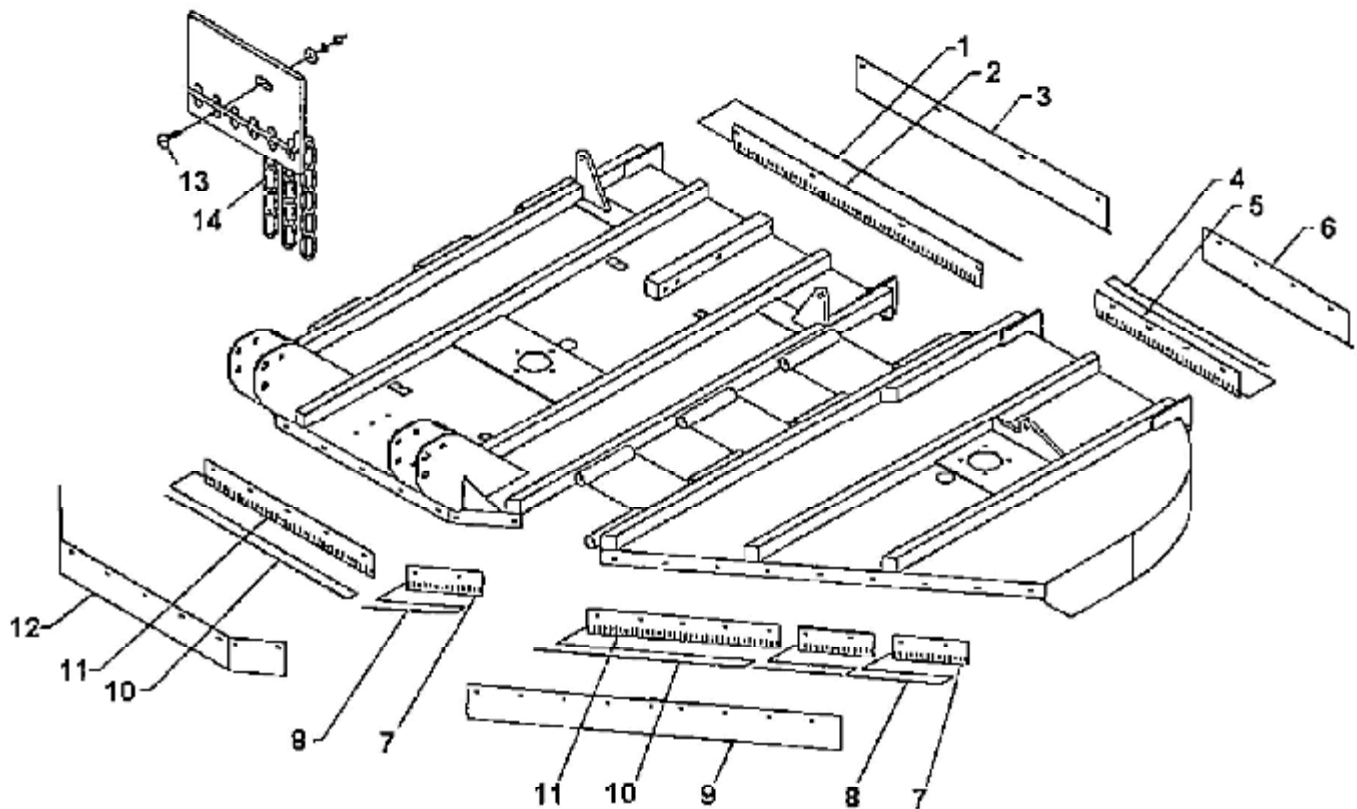

Item	Part No.	Description	Qty.
1	805462	ROD/CHAIN 58"	1
2	812090	CHAIN PLATE/REAR CENTER 54.75"	1
3	812094	BAND/REAR CENTER 54.25"	1
4	809483	ROD/CHAIN 37"	2
5	812089	CHAIN PLATE/REAR WING 35"	2
6	812093	BAND/REAR WING 35"	2
7	812088	CHAIN PLATE/FRONT 15.5"	6
8	809481	ROD/CHAIN 18"	6
9	812092	BAND/FRONT WING 77.68"	2
10	808484	ROD/CHAIN 43"	3
11	812087	CHAIN PLATE/FRONT 40.25"	3
12	812091	BAND/FRONT CENTER 65.25"	1
13	303839	BOLT/CARR 3/8 x 1-1/2	-
	303969	WASHER/FLAT 3/8	-
	303953	WASHER/LOCK 3/8	-
	304005	NUT/HEX 3/8 NG	-
14	806669	CHAIN - 5/16" 5 LINKS	-
	812096	FRONT & REAR CHAIN KIT	
	812097	FRONT & REAR BAND KIT	
	812098	FRONT BANDS & REAR CHAINS KIT	
	812099	FRONT CHAINS & REAR BANDS KIT	

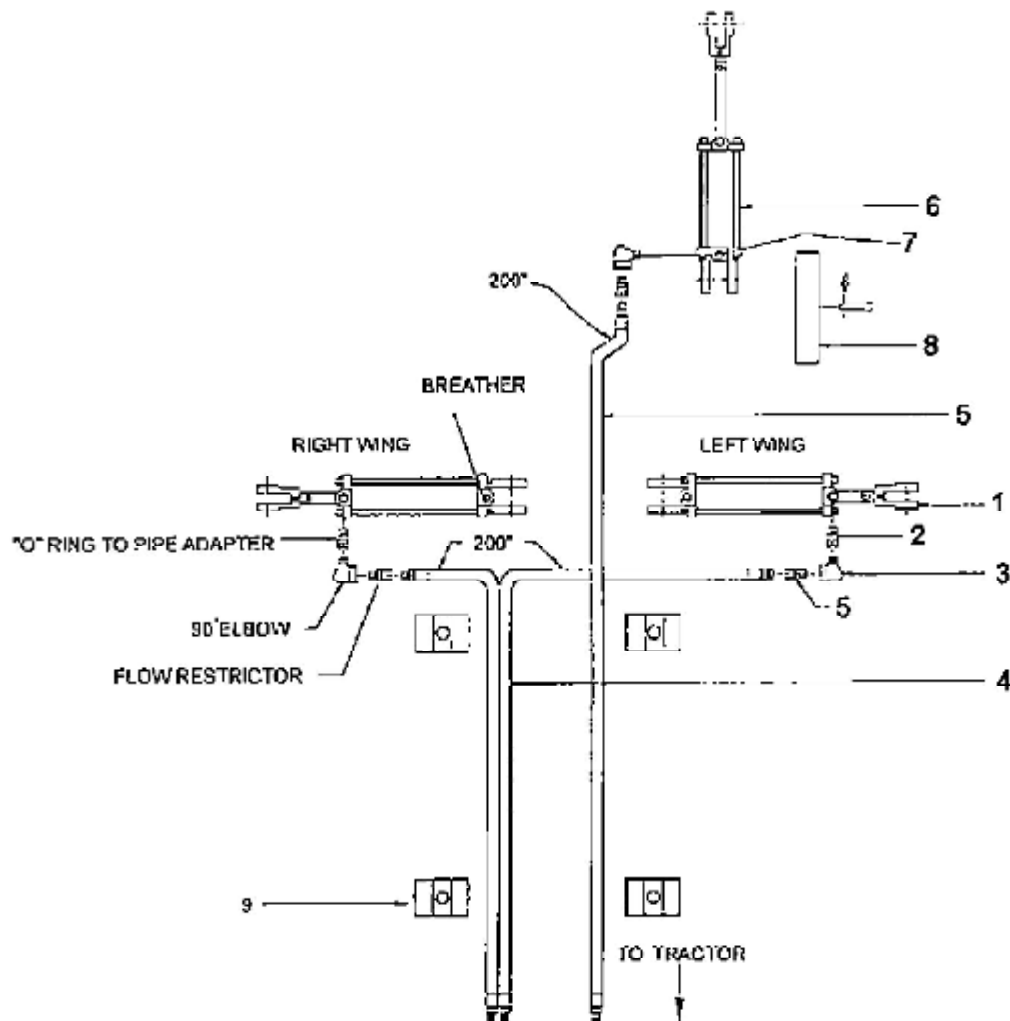
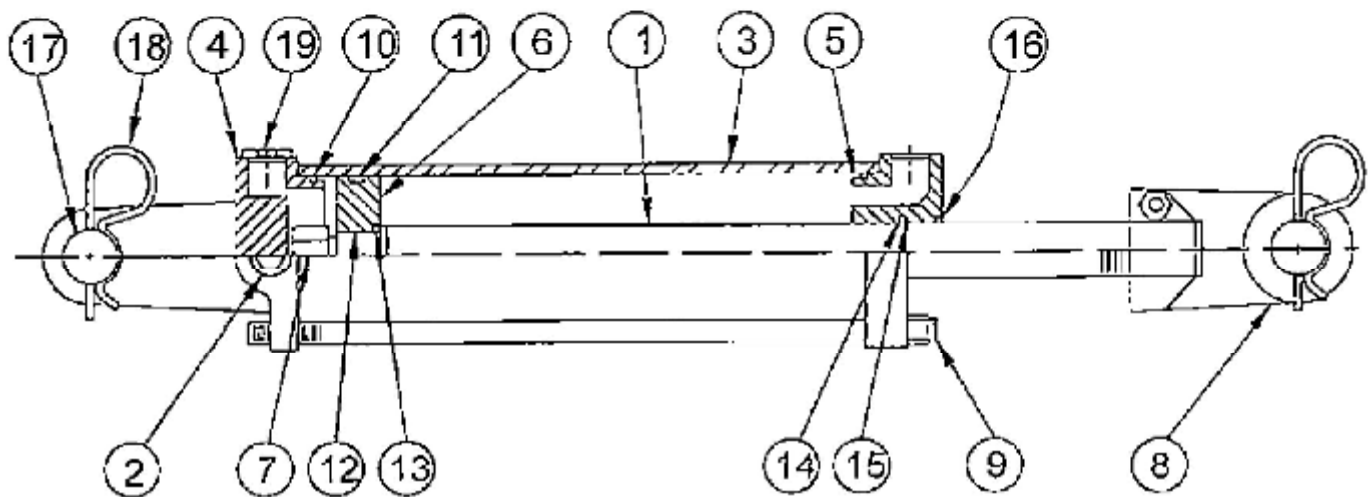

FIGURE 9 - HYDRAULIC SYSTEM COMPONENTS

Item	Part No.	Description	Qty.
1	806557	WING HYD CYLINDER 3" x 12", TIE ROD WITH SQUARE END	2
	811230	WING HYD CYLINDER 3" x 12", ROUND BARREL TYPE	2
2	814432	ADAPTER/HYD 8 - 8 SAE TO 1/2 NPT	6
3	207982	ST-ELBOW - 1/2" X 90° SWIVEL	2
4	208569	FLOW RESTRICTOR 1/2" NPT	2
5	809958	HYD HOSE ASSY 200"	3
6	505742	HYD CYLINDER 3 x 8 LIFT	1
7	811471	BREATHER	3
8	410047	CYLINDER STOP	1
	027189	RIVET/DRILLED 1/2 x 2-1/2	1
	304244	PIN/SPR LK 3/16 x 3-1/4	1
9	208259	HOSE - CLAMP	4
	303958	BOLT/CARR 1/2 x 1-1/4 GR5	4
	303955	WASHER/LOCK 1/2	4
	304007	NUT/HEX 1/2 NC	4
	809494	TRANSPORT HYD LIFT KIT	1
	809495	WING HYD LIFT KIT	1



"These Cylinders are Tie Rod Design with Square Ends"

FIGURE 10 HYDRAULIC CYLINDER COMPONENTS

Item	Part No.	Description	3 x 8 - Lift	3 x 12 - Wing
1	800572	ROD/PISTON 3" x 8"	1	-
	806963	ROD/PISTON 3" x 12"	-	1
2	800573	PIPE PLUG "O" RING SAE #8	3	2
3	800574	TUBE/CYL 3" x 8"	1	-
	806964	TUBE/CYL 3" x 12"	-	1
4	800575	BUTT/ 3"	1	1
5	800576	GLAND/ 3"	1	1
6	800577	PISTON	1	1
7	606941	NUT/ LOCK 3/4"	1	1
8	800584	CLEVIS ASSEMBLY 3" x 8" & 3" x 12"	1	1
9	800578	TIE ROD 3" x 8"	1	-
	806966	TIE ROD 3" x 12"	-	1
10	**	O-RING	2	2
11	**	O-RING	1	1
12	**	BU-WASHER	2	2
13	**	O-RING	1	1
14	**	O-RING	1	1
15	**	BU-WASHER	1	1
16	**	WIPER	1	1
17	606949	CLEVIS PIN 1" x 3-1/2"	2	2
18	304244	PIN/SPR LK 3/16" x 3-1/2"	4	4
19	806950	BREATHER	1	1
	800585	PACKING KIT (INCL. 10-16) 3" x 8" CYL	1	-
**	810054	PACKING KIT (INCL. 10-16) 3" x 12" CYL	-	1
	503742	3 x 8 TRANSPORT CYLINDER COMPLETE	-	-
	806557	3 x 12 WING CYLINDER COMPLETE	-	-

# 5 BOLT LAMINATED & AIRCRAFT WHEEL COMPONENTS

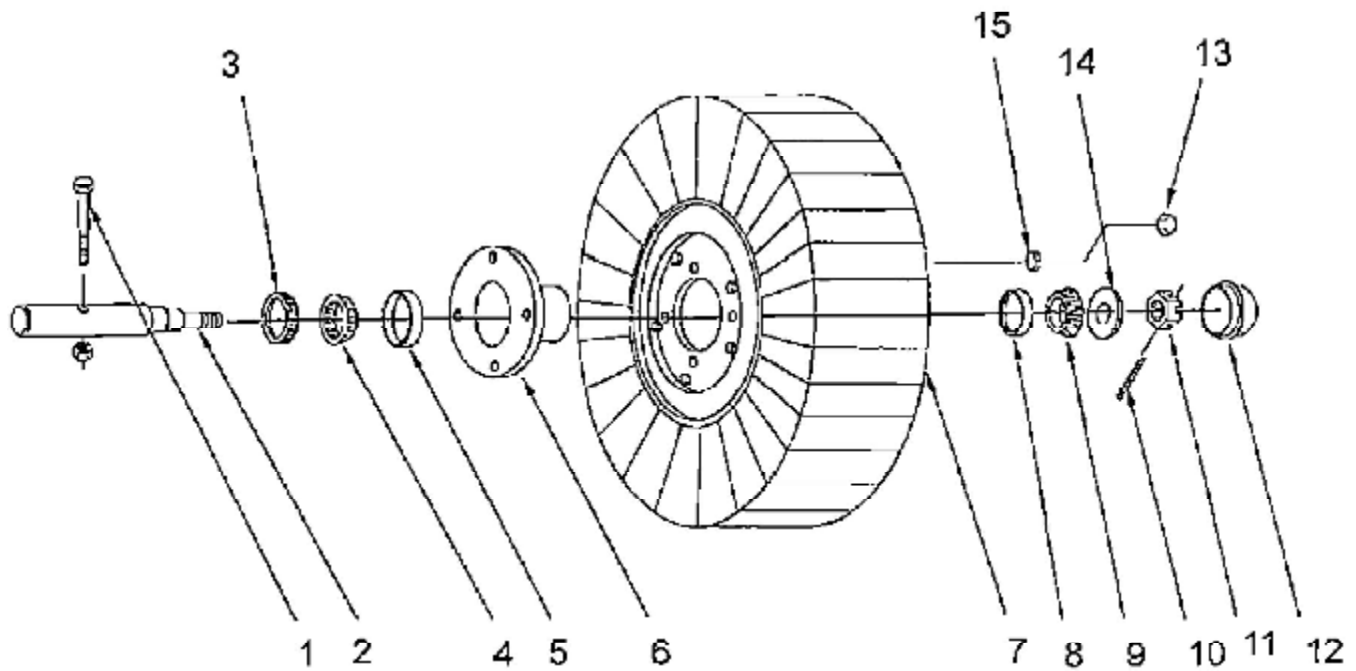

FIGURE 12 -- LAMINATED WHEEL COMPONENTS

Item	Part No.	Description	Qty.
1	303857	HHCS 1/2 x 3 GR5	1
	304020	NUT/HEX LOCK 1/2 NC	1
2	608532	SPINDLE/SINGLE ENDED	1
	608531	SPINDLE/DOUBLE ENDED	1
3	608530	SEAL/GREASE SINGLE LIP	1
4	608528	CONE/BRG LM48548	1
5	608527	CUP/BRG LM45810	1
6	608526	HUB/WHEEL 5 BOLT (INCL. 4&7)	1
7	608537	TIRE/LAMINATED 5-1/2 x 21 - 5 BOLT	1
	608536	TIRE/USED AIRCRAFT 5 BOLT	1
8	206332	CUP/BRG LM67010	1
9	811199	CONE/BRG LM67048	1
10	304094	PIN/COTTER 5/32 x 1-1/4	1
11	403853	NUT/HEX SLOTTED 3/4 - 16 UNF	1
12	608529	CAP/HUB	1
13	050843	NUT/HEX LUG 1/2 - 20 UNF	5
14	608550	WASHER/3/4 HVY HT	1
15	303955	WASHER/LOCK 1/2	5

## 4 BOLT LAMINATED WHEEL COMPONENTS

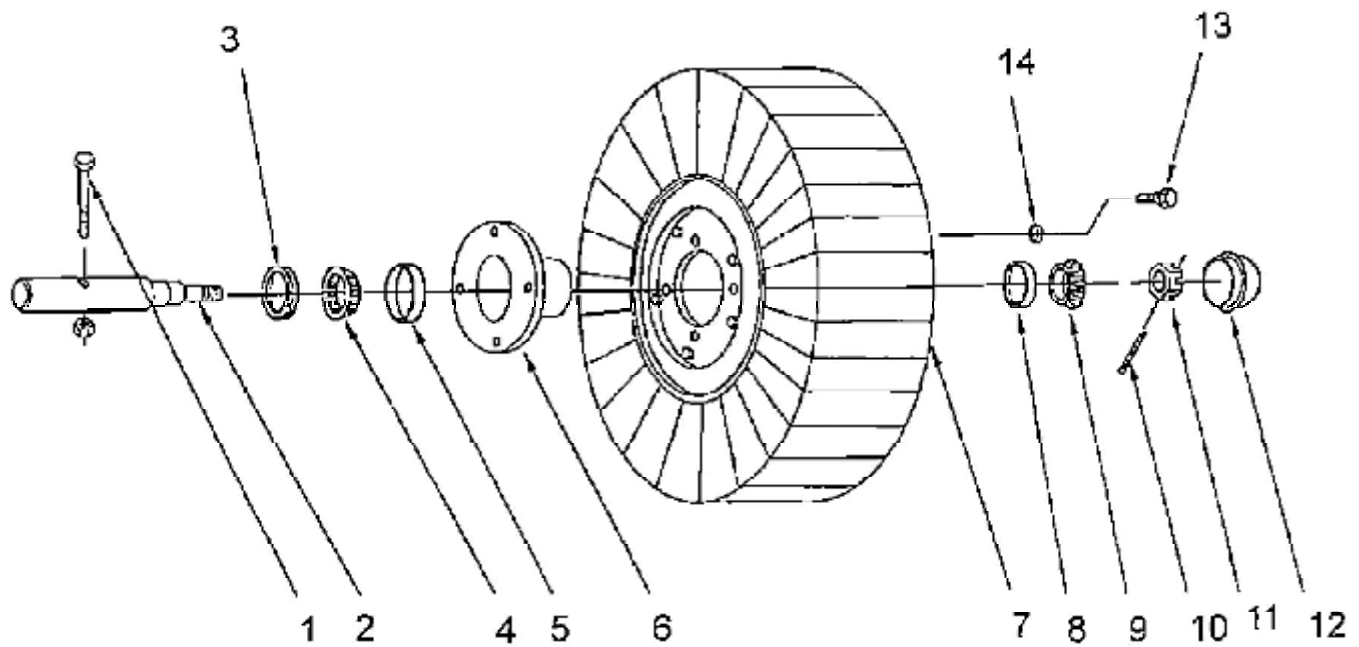

FIGURE 12 -- LAMINATED WHEEL COMPONENTS

Item	Part No.	Description	Qty.
1	303657	HHCS 1/2 x 3 GR5	1
	304020	NUT/HEX LOCK 1/2	1
2	807430	SPINDLE/SINGLE ENDED	1
	807431	SPINDLE/DOUBLE ENDED	1
3	038628	SEAL CR16069	
4	811199	CONE/BRG LM67048	1
5	206332	CUP/BRG LM67010	1
6	038640	HUB/WHEEL 4 BOLT (INCL. 4&7) W669	1
7	505695	TIRE/LAMINATED 5-1/2 x 21	1
	813785	TIRE/LAMINATED 5 x 18-11/16	1
8	206334	CUP/BRG LM11910	1
9	811200	CONE/BRG LM11949	1
10	304094	PIN/COTTER 5/32 x 1-1/4	1
11	403853	NUT/HEX SLOTTED 3/4 - 16 UNF	1
12	044797	CAP/HUB	1
13	304561	LUG BOLT 1/2 X 1 UNF GR5	4
14	303955	WASHER/LOCK 1/2	4



## 4 BOLT AIRCRAFT WHEEL COMPONENTS

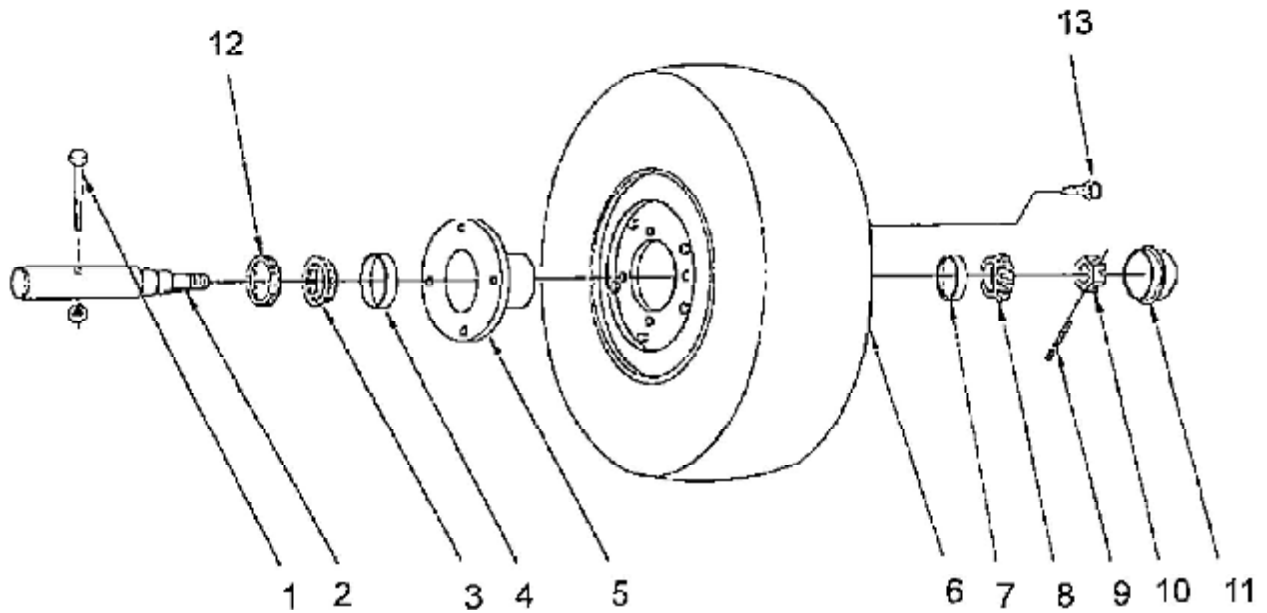

FIGURE 13 - AIRPLANE WHEEL COMPONENTS

Item	Part No.	Description	Qty.
1	303657	HHCS 1/2 x 3 GR5	1
	304020	NUT/HEX LOCK 1/2"	1
2	807430	SPINDLE/SINGLE ENDED	1
	807431	SPINDLE/DOUBLE ENDED	1
3	811199	CONE/BRG LM67048	1
4	206332	CUP/BRG LM67010	1
5	038640	HUB/WHEEL 4 BOLT (INCL. 4&7) W669	1
6	809338	TIRE/AIRPLANE	1
7	206334	CUP/BRG LM11910	1
8	811200	CONE/BRG LM11949	1
9	304094	PIN/COTTER 5/32 x 1-1/4	1
10	403853	NUT/HEX SLOTTED 3/4 - 16UNF	1
11	044787	CAP/HUB	1
12	038628	SEAL CR18059	1
13	403817	LUG-BOLT 1/2 - 20UNF x 1-1/2	4

## 5 BOLT PNEUMATIC WHEEL COMPONENTS

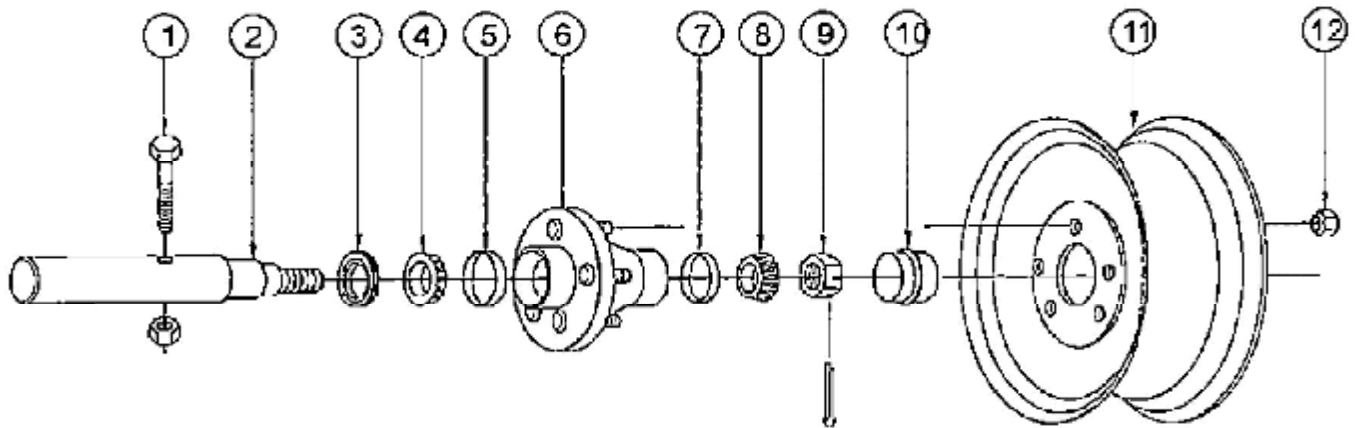

FIGURE 14 -- PNEUMATIC WHEEL COMPONENTS

**THIS WHEEL HUB HAS 11804 CAST ON BACK SURFACE NEAR SLOT ON LARGE DIAMETER - PRODUCED BY GROVE**

Item	Part No.	Description	Qty.
1	303657	HHCS 1/2 x 3 GR5	1
	304020	NUT/HEX LOCK 1/2" NG	1
2	608532	SPINDLE/SINGLE ENDED	1
	608531	SPINDLE/DOUBLE ENDED	1
3	608530	SEAL/SINGLE LIP	1
4	608528	CONE/BRG 1 M4R54R	1
5	608527	CUP/BRG LM45B10	1
6	608526	HUB/WHEEL 5 BOLT 5.50 BC (INCL. 5&7)	1
7	208332	CUP/BRG LM67010	1
8	811199	CONE/BRG LM6704B	1
9	403853	NUT/HEX SLOTTED 3/4 - 16UNF	1
10	608529	CAP/HUB	1
11	038608	RIM/WHL 15 x 5 - 5 BOLT	1
12	050843	NUT/HEX LUG 1/2 - 20 UNF	5
-	304938	TIRE 7.60 -15 - 6 PR (NOT SHOWN)	1

## 5 BOLT PNEUMATIC WHEEL COMPONENTS

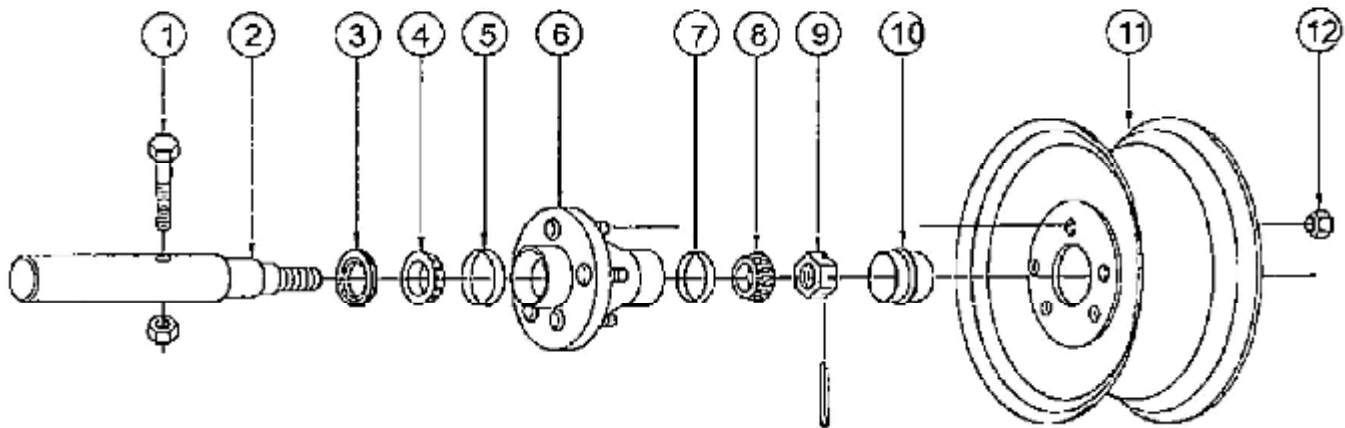
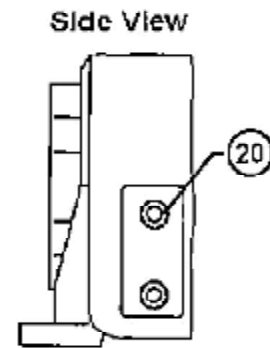
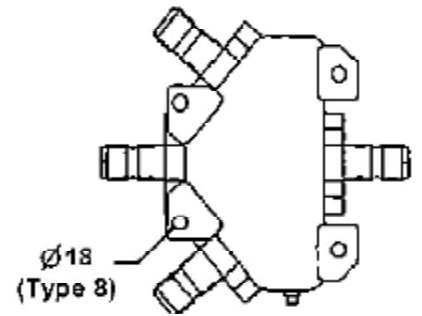
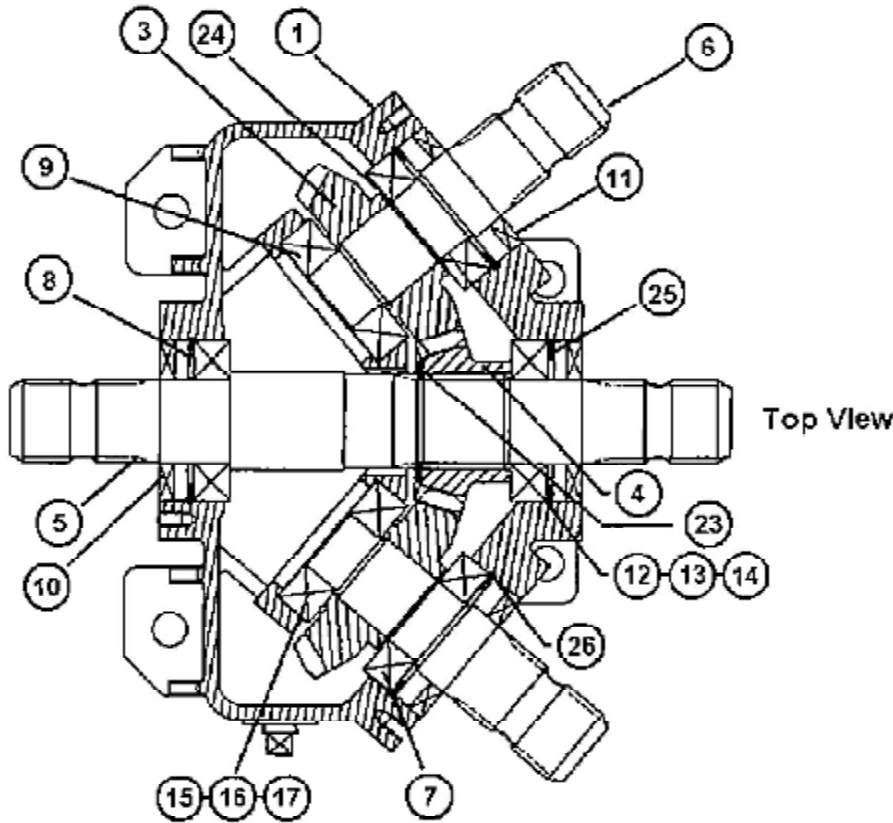

FIGURE 15 -- PNEUMATIC WHEEL COMPONENTS

**THIS WHEEL HUB HAS 280532 CAST ON BACK SURFACE - PRODUCED BY ARMSTRONG**

Item	Part No.	Description	Qty.
1	303657	HHCS 1/2 x 3 GR5	1
	304020	NUT/LGX LOCK 1/2" NO	1
2	807432	SPINDLE/SINGLE ENDED	1
	807433	SPINDLE/DOUBLE ENDED	1
3	046178	SEAL/TRIPLE LIP CR16286	1
4	811199	CONE/BRG LM67048	1
5	206332	CUP/BRG LM67010	1
6	046176	HUB/WHEEL 5 BOLT 5.50 BC (INCL. 5&7)	1
7	206334	CUP/BRG LM11910	1
8	811200	CONE/BRG LM11949	1
9	403853	NUT/HEX SLOTTED 3/4 - 16UNF	1
10	044797	CAP/HUB	1
11	033608	RIM/WHL 15 x 5 - 5 BOLT	1
12	050843	NUT/LUG 1/2 UNF	5
-	304938	TIRE 7.60 -15 - 6 PR (NOT SHOWN)	1

# Spitter Gearbox



**Oil Capacity- 60oz. (1.8 liters)**

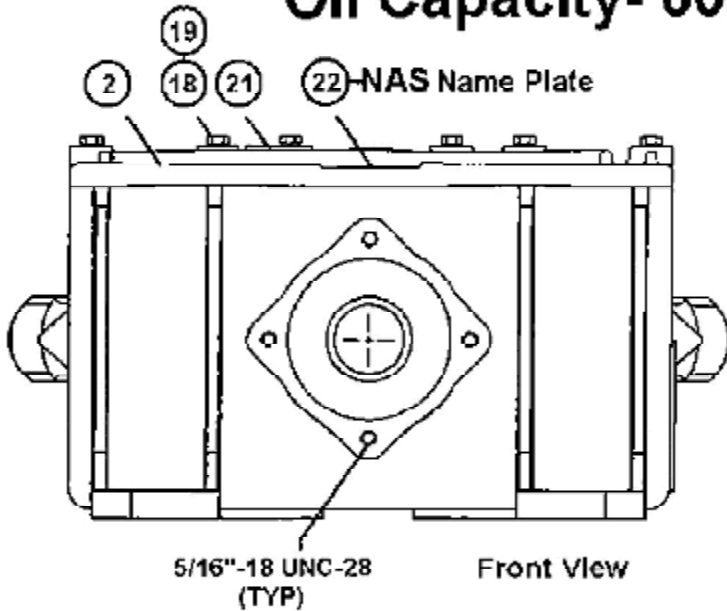

To properly identify brand of gearbox, this symbol will be on top of gearbox housing.

608300 (540-RPM)

RCD 90 #250666

Ratio 1:1.2

---

608304 (1000-RPM)

RCD 90 #250667

Ratio 1.2:1

# (608300 540-RPM) - (608304 1000-RPM) Splitter Gearbox

Item	Part # 540-RPM	Part # 1000-RPM	Description	Qty
1	608379	608379	Housing RCD 90	1
2	608380	608380	Cover	1
3	608381	-----	Pinion (20-T 540-RPM)	2
	-----	608409	Pinion (24-T 1000-RPM)	2
4	608382	-----	Gear (24-T 540-RPM)	1
	-----	608410	Gear (20-T 1000-RPM)	1
5	608383	608383	Input Shaft 1.75" - 20 Spline	1
6	608384	608384	Output Shaft 1.75" - 20 Spline	2
7	505123	505123	Ball Bearing 6208	2
8	807077	807077	Ball Bearing 6209	2
9	505297	505297	Ball Bearing 6307	2
10	608330	608330	Input Seal	2
11	608388	608388	Output Seal	2
12	608313	608313	Input Shim 0.1mm	Kit
13			Input Shim 0.2mm	Kit
14			Input Shim 0.5mm	Kit
15	608314	608314	Output Shim 0.1mm	Kit
16			Output Shim 0.2mm	Kit
17			Output Shim 0.5mm	Kit
18	608395	608395	Screw M8 X 35	6
19	608349	608349	Lockwasher M8	6
20	608396	608396	Socket Head Plug 3/8" - 18 NPT	2
21	608350	608350	Pressure Relief Plug 1/2"-14NPT	1
22	-----	-----	I.D.TAG "NOT A SERVICE PART"	-----
23	608353	608353	Retaining Ring 50mm	1
24	608397	608397	Retaining Ring 40mm	2
25	608354	608354	Retaining Ring 85mm	2
26	608398	608398	Retaining Ring 80mm	2
	608300	608304	COMPLETE GEARBOX	

# Left Wing Gearbox

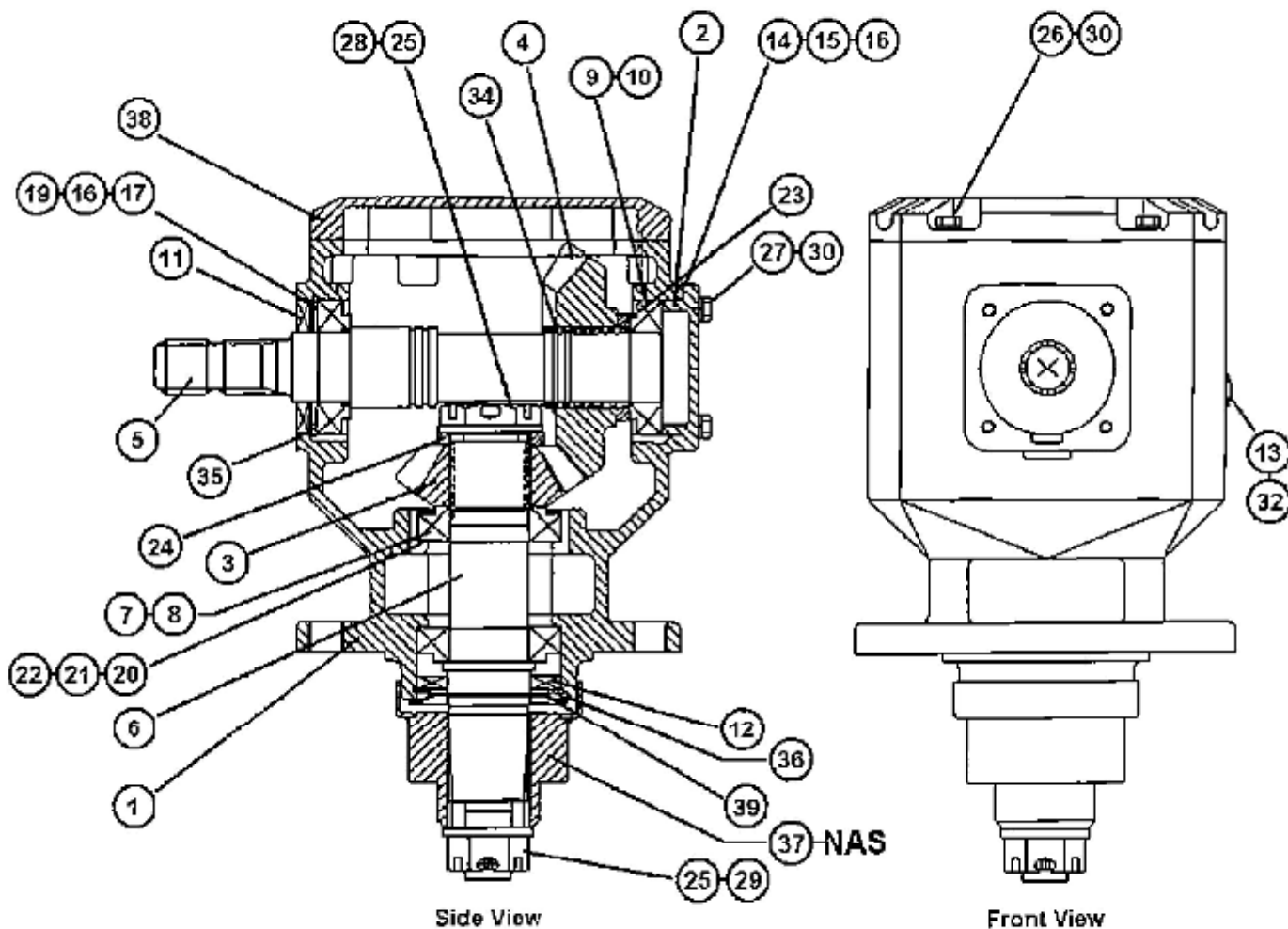

**Oil Capacity- 57oz. / (1.7 liters)**

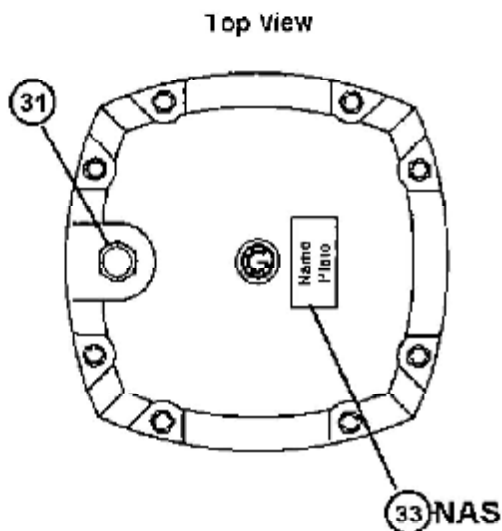

To properly identify brand of gearbox, this symbol will be on top of gearbox housing.

**608301 (540-RPM)**

**RC 100 #251083**

**Ratio 1:1.46**

**608307 (1000-RPM)**

**RC 100 #251172**

**Ratio**

**(608301 540-RPM) - (608307 1000-RPM)****Left Wing Gearbox**

Item	Part # 540-RPM	Part # 1000-RPM	Description	Qty
1	608320	608320	Housing RC-100 Series	1
2	608321	608321	Blank Cap	1
3	608322	-----	Output Pinion (13-T 540 RPM)	1
	-----	608411	Output Pinion (18-T 1000-RPM)	1
4	608323	-----	Input Gear (19-T 540 RPM)	1
	-----	608412	Input Gear (22-T 1000-RPM)	1
5	608324	608324	Input Shaft	1
6	608325	608325	Output Shaft	1
7	w/brg	w/brg	Bearing Cup 30210	2
8	505303	505303	Cone Bearing 30210	2
9	w/brg	w/brg	Bearing Cup 30209	2
10	505974	505974	Cone Bearing 30209	2
11	608330	608330	Input Seal	1
12	608331	608331	Output Seal	1
13	608332	608332	O-Ring	1
14	608317	608317	Gasket 0.2mm	Kit
15			Gasket 0.3mm	Kit
16			Gasket 0.5mm	Kit
17	608318	608318	Input Shim 0.1mm	Kit
18			Input Shim 0.2mm	Kit
19			Input Shim 0.5mm	Kit
20	608319	608319	Output Shim 0.1mm	Kit
21			Output Shim 0.2mm	Kit
22			Output Shim 0.5mm	Kit
23	608342	608342	Spacer	1
24	608343	608343	Spacer	1
25	608344	608344	Cotter Pin	2
26	608345	608345	Hex Cap Screw M8 - 1.25 X 25	8
27	608346	608346	Hex Cap Screw M8 - 1.25 X 30	4
28	608347	608347	Slotted Nut 1-3/8" - 18 UNEF	1
29	608348	608348	Slotted Nut M30 X 2 - 6H	1
30	608349	608349	Lockwasher M8	12
31	608350	608350	Pressure Relief Plug 1/2"-14NPT	1
32	608351	608351	Oil Site Gauge A10	1
33	-----	-----	I.D. Tag "NOT A SERVICE PART"	-----
34	608353	608353	External Retaining Ring	1
35	608354	608354	External Retaining Ring 85	1
36	608355	608355	External Retaining Ring 90	1
37	-----	-----	Hub "NOT A SERVICE PART"	-----
38	608357	608357	Inspection Cover	1
39	608358	608358	Seal Protector	1
	608301	608307	COMPLETE GEARBOX	

# R.H. Wing Gearbox

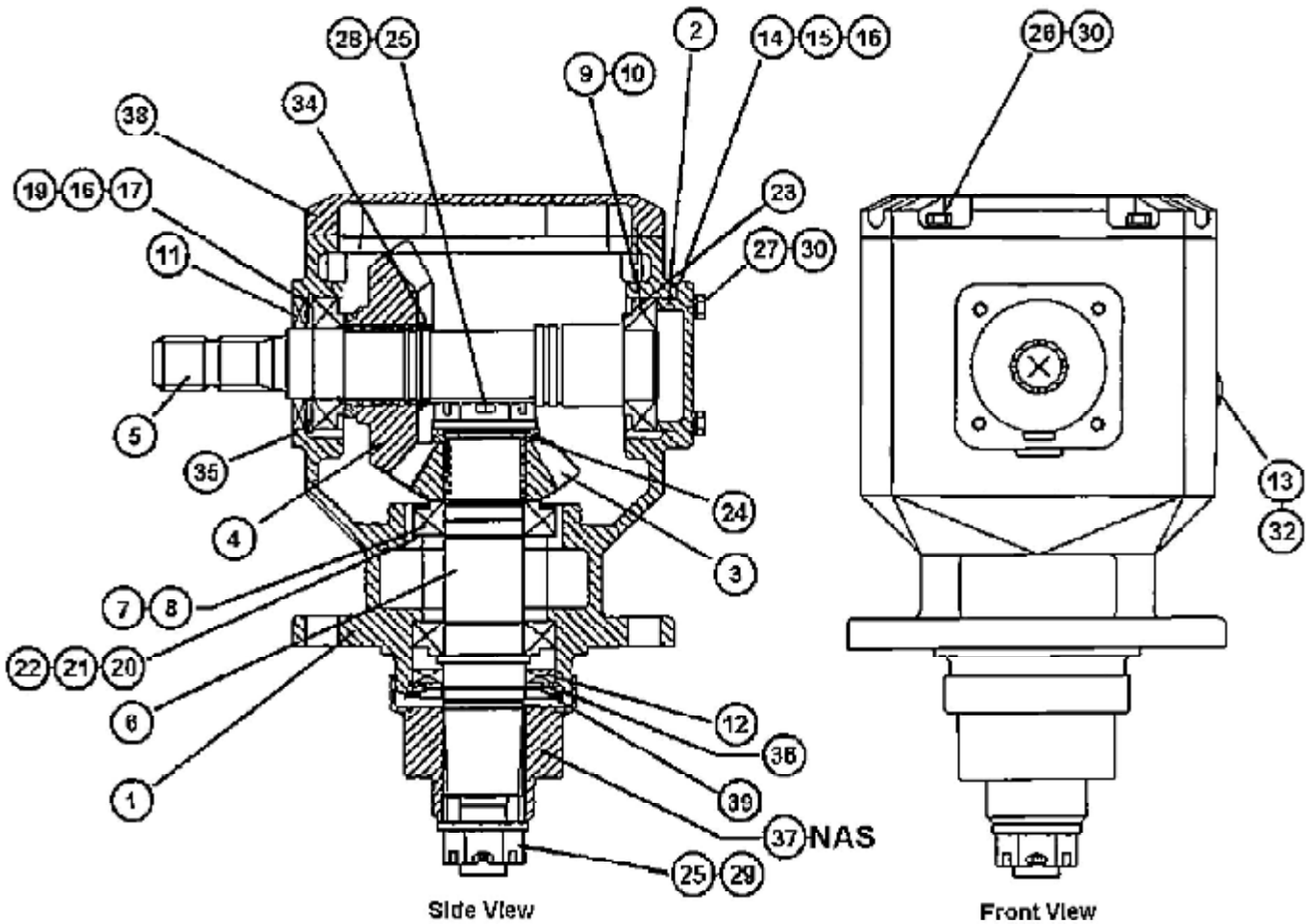

**Oil Capacity- 57oz. / (1.7 liters)**

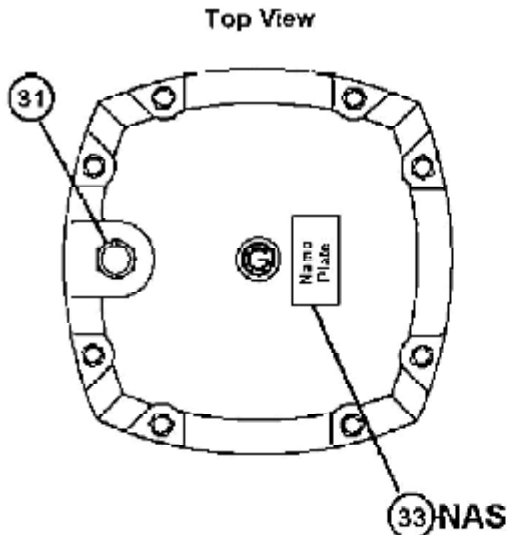

To properly identify brand of gearbox, this symbol will be on top of gearbox housing.

608302 (540-RPM)

RC 100 #251060

Ratio 1:1.46

---

608305 (1000-RPM)

RC 100 #251171

Ratio



**(608302 540-RPM) - (608305 1000-RPM)****Right Wing Gearbox**

Item	Part # 540-RPM	Part # 1000-RPM	Description	Qty
1	608320	608320	Housing RC-100 Series	1
2	608321	608321	Blank Cap	1
3	608322	-----	Output Pinion (13-T 540-RPM)	1
	-----	608411	Output Pinion (18-T 1000-RPM)	1
4	608323	-----	Input Gear (19-T 540-RPM)	1
	-----	608412	Input Gear (22-T 1000-RPM)	1
5	608324	608324	Input Shaft	1
6	608325	608325	Output Shaft	1
7	w/brg	w/brg	Bearing Cup 30210	2
8	505303	505303	Cone Bearing 30210	2
9	w/brg	w/brg	Bearing Cup 30209	2
10	505974	505974	Cone Bearing 30209	2
11	608330	608330	Input Seal	1
12	608331	608331	Output Seal	1
13	608332	608332	O-Ring	1
14	608317	608317	Gasket 0.2mm	Kit
15			Gasket 0.3mm	Kit
16			Gasket 0.5mm	Kit
17	608318	608318	Input Shim 0.1mm	Kit
18			Input Shim 0.2mm	Kit
19			Input Shim 0.5mm	Kit
20	608319	608319	Output Shim 0.1mm	Kit
21			Output Shim 0.2mm	Kit
22			Output Shim 0.5mm	Kit
23	608342	608342	Spacer	1
24	608343	608343	Spacer	1
25	608344	608344	Cotter Pin	2
26	608345	608345	Hex Cap Screw M8 - 1.25 X 25	8
27	608346	608346	Hex Cap Screw M8 - 1.25 X 30	4
28	608347	608347	Slotted Nut 1-3/8" - 18 UNEF	1
29	608348	608348	Slotted Nut M30 X 2 - 6H	1
30	608349	608349	Lockwasher M8	12
31	608350	608350	Pressure Relief Plug 1/2"-14NPT	1
32	608351	608351	Oil Site Gauge A10	1
33	-----	-----	I.D. Tag "NOT A SERVICE PART"	-----
34	608353	608353	External Retaining Ring	1
35	608354	608354	External Retaining Ring 85	1
36	608355	608355	External Retaining Ring 90	1
37	-----	-----	Hub "NOT A SERVICE PART"	-----
38	608357	608357	Inspection Cover	1
39	608358	608358	Seal Protector	1
	608302	608305	COMPLETE GEARBOX	

# Center Deck Gearbox

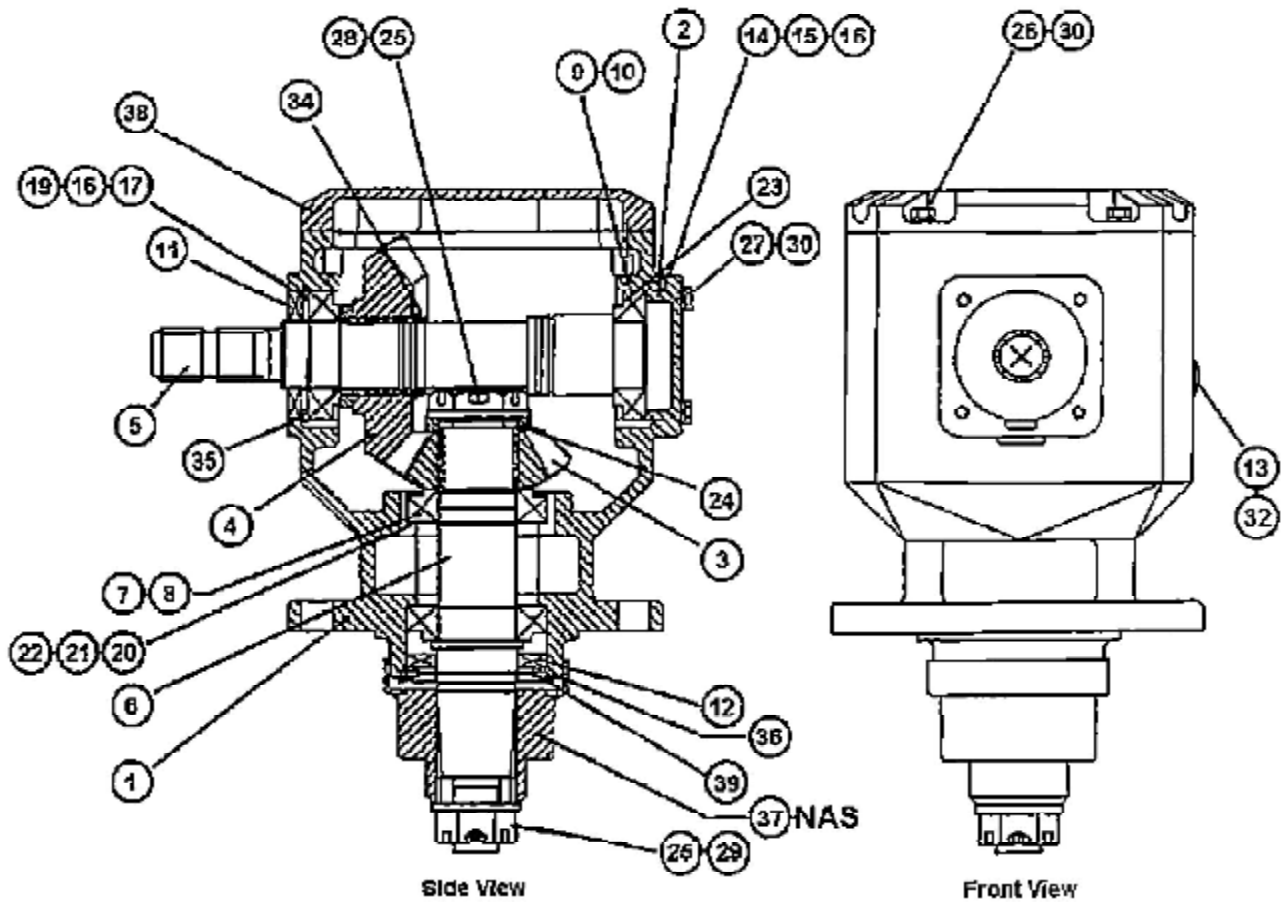

**Oil Capacity- 57oz. (1.7 liters)**

Top View

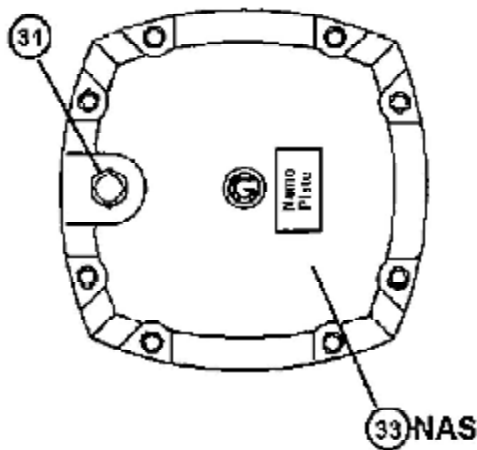

To properly identify brand of gearbox, this symbol will be on top of gearbox housing.

**608302 (540-RPM)**

**RC 100 #251060**

**Ratio 1:1.46**

**608306 (1000-RPM)**

**RC 100 #251173**

**Ratio**

**(608302 540-RPM) - (608306 1000-RPM)****Center Gearbox**

Item	Part # 540-RPM	Part # 1000-RPM	Description	Qty
1	608320	608320	Housing RC-100 Series	1
2	608321	608321	Blank Cap	1
3	608322	-----	Output Pinion (13-T 540-RPM)	1
	-----	608413	Output Pinion (18-T 1000-RPM)	1
4	608323	-----	Input Gear (19-T 540-RPM)	1
	-----	608414	Input Gear (18-T 1000-RPM)	1
5	608324	608324	Input Shaft	1
6	608325	608325	Output Shaft	1
7	w/brg	w/brg	Bearing Cup 30210	2
8	505303	505303	Cone Bearing 30210	2
9	w/brg	w/brg	Bearing Cup 30209	2
10	505974	505974	Cone Bearing 30209	2
11	608330	608330	Input Seal	1
12	608331	608331	Output Seal	1
13	608332	608332	O-Ring	1
14	608317	608317	Gasket 0.2mm	Kit
15			Gasket 0.3mm	Kit
16			Gasket 0.5mm	Kit
17	608318	608318	Input Shim 0.1mm	Kit
18			Input Shim 0.2mm	Kit
19			Input Shim 0.5mm	Kit
20	608319	608319	Output Shim 0.1mm	Kit
21			Output Shim 0.2mm	Kit
22			Output Shim 0.5mm	Kit
23	608342	608342	Spacer	1
24	608343	608343	Spacer	1
25	608344	608344	Cotter Pin	2
26	608345	608345	Hex Cap Screw M8 - 1.25 X 25	8
27	608346	608346	Hex Cap Screw M8 - 1.25 X 30	4
28	608347	608347	Slotted Nut 1-3/8" - 18 UNEF	1
29	608348	608348	Slotted Nut M30 X 2 - 6H	1
30	608349	608349	Lockwasher M8	12
31	608350	608350	Pressure Relief Plug 1/2"-14NPT	1
32	608351	608351	Oil Site Gauge A10	1
33	-----	-----	I.D. Tag "NOT A SERVICE PART"	-----
34	608353	608353	External Retaining Ring	1
35	608354	608354	External Retaining Ring 85	1
36	608355	608355	External Retaining Ring 90	1
37	-----	-----	Hub "NOT A SERVICE PART"	-----
38	608357	608357	Inspection Cover	1
39	608358	608358	Seal Protector	1
	608302	608306	COMPLETE GEARBOX	

# C.V. Driveline Components

**809696 - 540 RPM**  
**809697 - 1000 RPM**

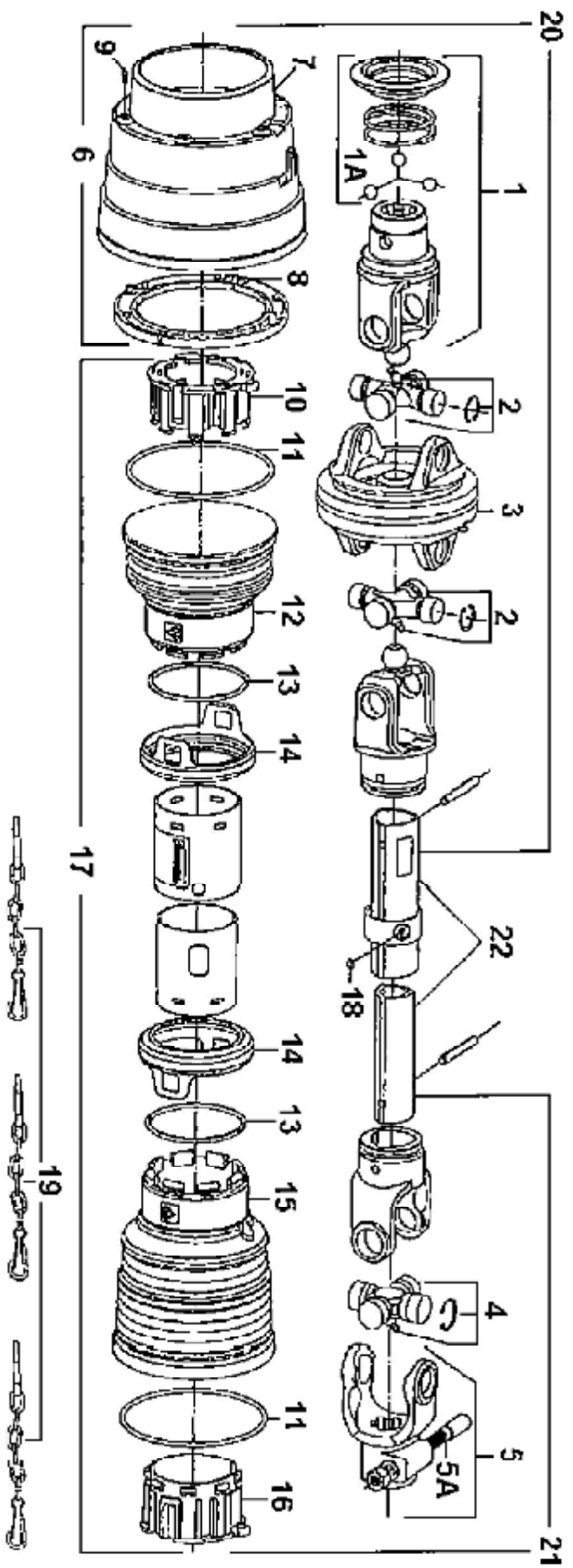

**C.V. Driveline Components**  
**809696 - 540 RPM**  
**809697 - 1000 RPM**

Item	Part # 540-RPM	Part # 1000-RPM	Description	Qty
1	699524	-----	TRACTOR YOKE W/COLLAR 1-3/8" 6-S	1
	-----	699523	TRACTOR YOKE W/COLLAR 1-3/8" 21-S	
1A	699526	699526	PULL COLLAR KIT	1
2	699528	-----	CROSS KIT G08	2
	-----	699527	CROSS KIT G06	
3	699541	-----	CENTRALIZER 80	1
	-----	699540	CENTRALIZER 60	
4	809699	-----	CROSS KIT 80	1
	-----	807059	CROSS KIT 60	
5	809709	813914	IMPLEMENT YOKE 1-3/4" 20-Spline w/Bolt	1
5A	699529	699529	CONICAL BOLT KIT	1
6	699590	699591	C.V. MASTER SHIELD & BRG. KIT	1
7	699627	699628	C.V. SOFT CONE	1
8	699565	699556	BRG/SOFT CONE C.V.	1
9	699568	699568	SELF TAPPING SCREW	6
10	699564	699563	OUTER SHIELD BRG	1
11	699571	699570	STIFFENING RING	2
12	699548	699550	SHORT CONE	1
13	699573	699572	STOP RING	2
14	699594	699593	SAFETY SLEEVE	2
15	699551	699543	STANDARD CONE	1
16	699559	699558	INNER SHIELD BRG.	1
17	699588	699575	COMPLETE SHIELD (Less CV Cone)	1
18	699532	699532	GREASE ZERK	1
19	505103	505103	SAFETY CHAIN	3
20	699596	699595	TRACTOR HALF SHAFT (Complete w/CV)	1
21	699694	699613	IMPLEMENT HALF SHAFT (Complete)	1
22	699629	699630	EXT. TUBE KIT (Includes both Tubes)	1
	809696	809697	COMPLETE C.V. DRIVELINE	

# 813867 Wing Driveline

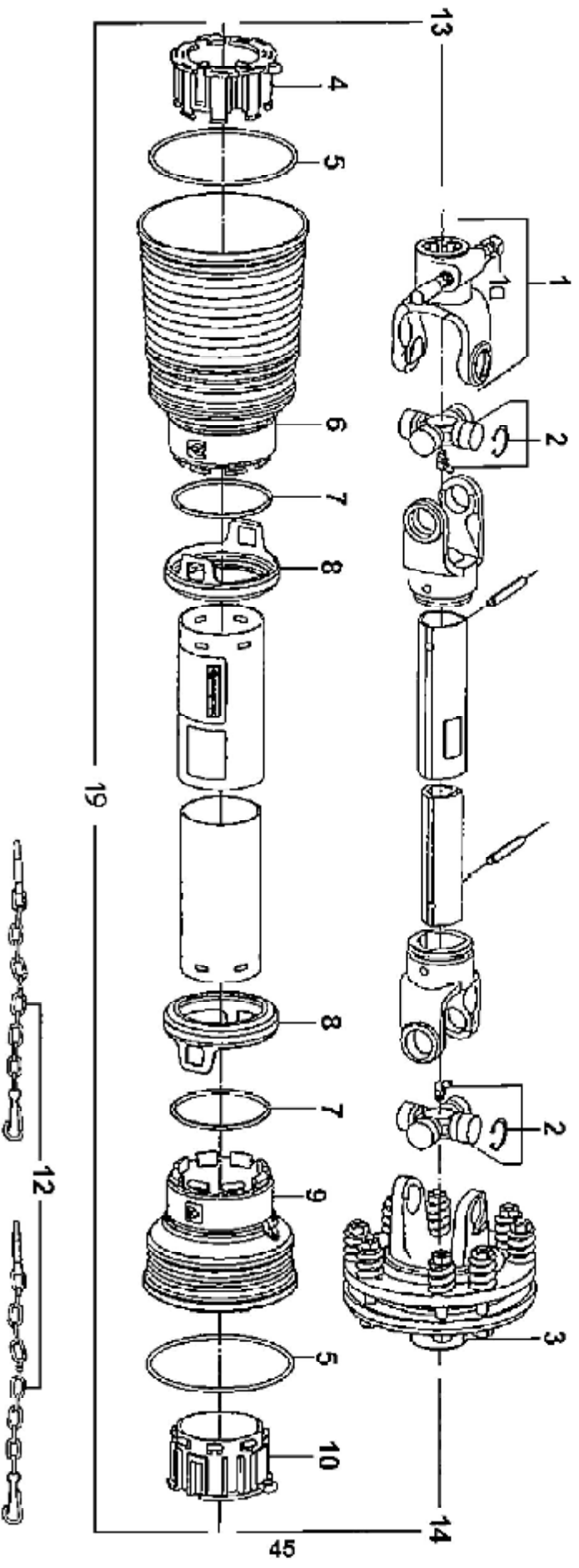

## 813867 Wing Driveline

Item	Part #	Description	Qty
1	813914	GEARBOX YOKE 1-3/4" 20-Spline	1
1A	699529	CONICAL BOLT KIT	1
2	807059	CROSS KIT 60	2
3	699502	COMPLETE SLIPCLUTCH 1-3/8" 6-S	1
4	699563	OUTER SHIELD BRG.	1
5	699570	STIFFENING RING	2
6	699543	LONG CONE	1
7	699572	STOP RING	2
8	699593	SAFETY SLEEVE	2
9	699550	SHORT CONE	1
10	699558	INNER TUBE BRG.	1
11	699576	COMPLETE SHIELD	1
12	505103	SAFETY CHAIN	2
13	699598	OUTER HALF SHAFT (Complete)	1
14	699610	INNER HALF SHAFT (Complete)	1
	813867	COMPLETE DRIVELINE W/CLUTCH	

# 813868 Connector Shaft

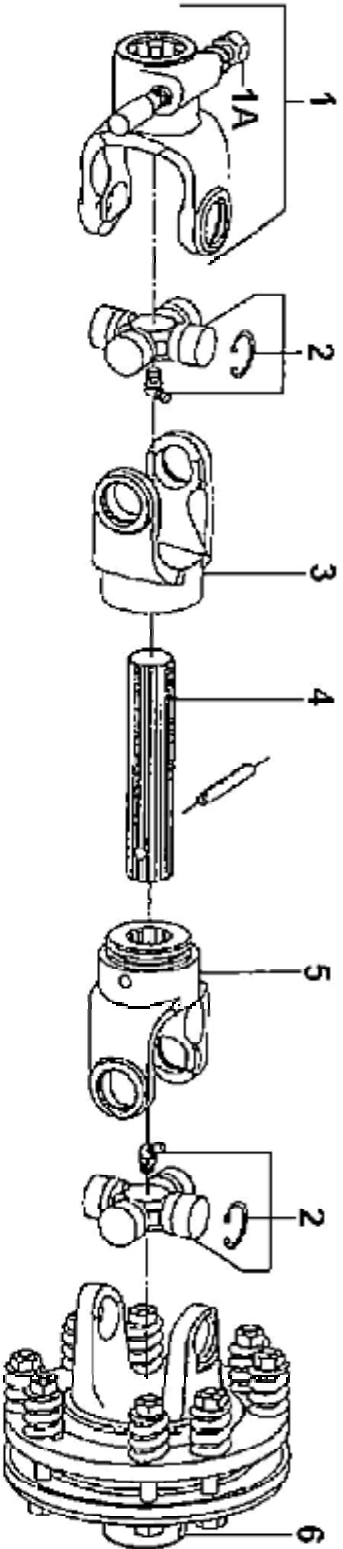

Item	Part #	Description	Qty
1	813914	GEARBOX YOKE 1-3/4" 20-Spline	1
1A	699529	CONICAL BOLT KIT	1
2	807059	CROSS KIT 60	2
3	699522	OUTER SPLINED YOKE 60	1
4	699539	SPLINED SHAFT 35-Z12	1
5	699521	INNER SPLINED YOKE 60	1
6	699502	COMPLETE SLIPCLUTCH	1
813868		COMPLETE CONNECTOR SHAFT	



# 699502 Slipclutch Components

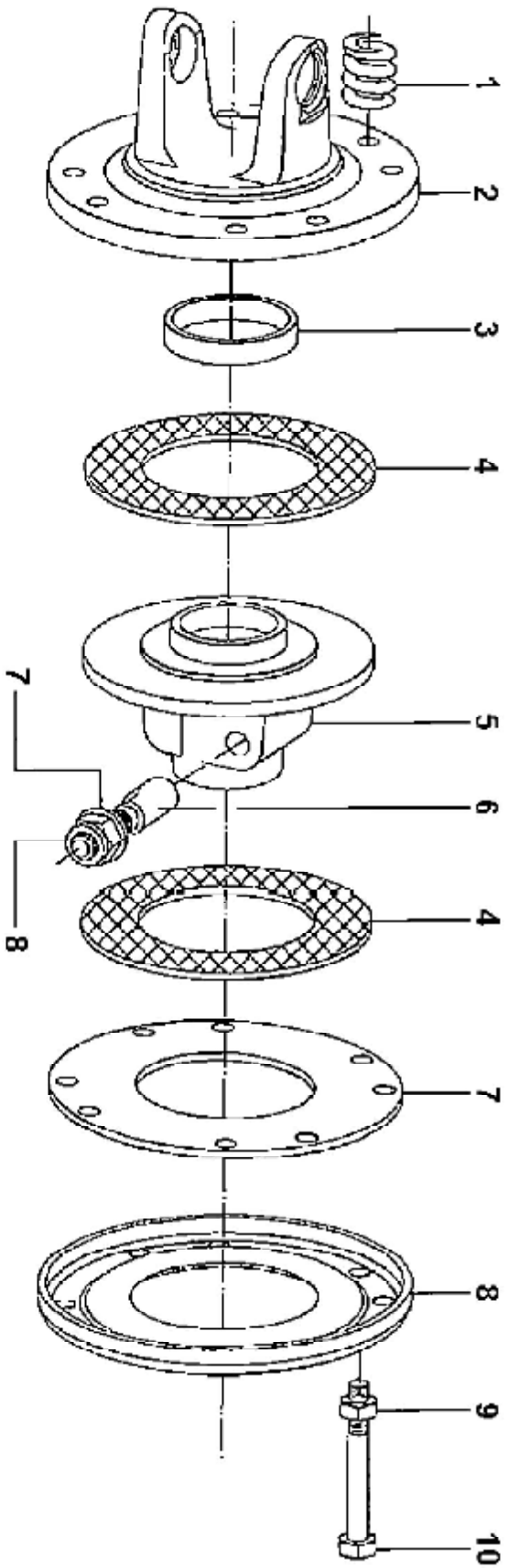

Item	Part #	Description	Qty
1	699518	SPRING	8
2	699509	FLANGE WITH YOKE	1
3	699592	SLEEVE	1
4	699520	FRICITION DISC	2
5	699510	HUB WITH FLANGE 1-3/8" 6-Spline	1
6	699530	CONICAL BOLT KIT	1
7	699514	INNER PLATE	1
8	699516	PRESSURE PLATE	1
9	699537	M10 HEX NUT	8
10	699534	HH BOLT M10 X 90	8
699502 COMPLETE SLIPCLUTCH			



## LIMITED WARRANTY

TAYLOR PITTSBURGH MFG., INC. the manufacturer, warrants only to the Original Purchaser that this equipment, under normal use and service, will be free from defects in material and workmanship for one (1) year from date of purchase providing this equipment is purchased for individual and not for commercial use. Warranty for commercial usage is 90 days. This warranty does not apply to any equipment which has been damaged or which has been subjected to abuse, misuse, negligence, abnormal wear and tear, alterations, tampering, or failure to follow operating instructions. This warranty does not cover any product or parts not manufactured by TAYLOR PITTSBURGH MFG., Inc.

Under this warranty, the manufacturer will repair or replace any part which the manufacturer determines has failed during the period of the warranty due to defects in material or workmanship. After approval by the manufacturer, the equipment or defective part must be returned to TAYLOR PITTSBURGH MFG., INC., Winfield, AL 35594.

Warranty coverage and performance is expressly conditioned on the return of the completed registration form to TAYLOR PITTSBURGH., INC., Winfield, AL 35594.

PURCHASER'S EXCLUSIVE REMEDY FOR BREACH OF WARRANTY, OTHER DEFECT, OR CONDUCT GIVING RISE TO LIABILITY SHALL BE THE REPAIR OR REPLACEMENT OF THE PRODUCT SOLD, AND THE MANUFACTURER UNDER NO CIRCUMSTANCES SHALL BE LIABLE FOR ECONOMIC LOSS OR INCIDENTAL OR CONSEQUENTIAL DAMAGES. THE MANUFACTURER DISCLAIMS ALL IMPLIED WARRANTIES, INCLUDING THE WARRANTY OF MERCHANTABILITY AND FITNESS FOR PURPOSE.

Taylor Pittsburgh Mfg., Inc. reserves the right to make improvements and changes in specifications without notice or obligation to modify previous sold units.

This manual describes the proper assembly procedures for your implement and furnishes operating and maintenance recommendations to help you obtain long and satisfactory service.

**TAYLOR PITTSBURGH MFG.**  
**FIVE YEAR LIMITED GEARBOX WARRANTY**

Taylor Pittsburgh Mfg., warrants to the original purchaser of any new Taylor Pittsburgh product equipped with a Gearbox, a Gearbox only- limited Five (5) year warranty, for non-commercial, non-state, non-municipalities, and non-rental use, and for 90 days for commercial, non-rental use or a 30-day warranty is offered for rental use.

Under no circumstances will this warranty apply in the event that the product, in good faith opinion of Taylor Pittsburgh, has been subjected to improper operation, improper maintenance, misuse, fire or an accident. This warranty does not apply in the event that the product has been materially modified or repaired by someone not authorized prior to repair by Taylor Pittsburgh. This warranty does not cover normal wear and tear, or normal maintenance items. This warranty also does not cover repairs made with parts other than those obtainable through Taylor Pittsburgh.

This warranty is extended solely to the original purchaser of the product. Should the original purchaser sell or otherwise transfer this product to a third party, this Warranty does not transfer to the third-party purchaser in any way. There are no third-party beneficiaries of this Warranty.

Taylor Pittsburgh's obligation under this Warranty are limited to, at Taylor Pittsburgh's option, the repair or replacement of the product if Taylor Pittsburgh in its sole discretion deems it to be defective or in noncompliance with this Warranty. The product must be returned to Taylor Pittsburgh with proof of purchase within thirty (30) days after such defect or noncompliance is discovered or should have been discovered, routed thru the dealer and distributor from whom the purchase was made, transportation charges prepaid.

THERE ARE NO OTHER REMEDIES UNDER THIS WARRANTY. THE REMEDY OF REPAIR OR REPLACEMENT IS THE SOLE AND EXCLUSIVE REMEDY UNDER THIS WARRANTY.

THERE ARE NO WARRANTIES, WHICH EXTEND BEYOND THE DESCRIPTION ON THE FACE OF THIS WARRANTY. TAYLOR PITTSBURGH MAKES NO OTHER WARRANTY, EXPRESS OR IMPLIED, AND TAYLOR PITTSBURGH SPECIFICALLY DISCLAIMS ANY IMPLIED WARRANTY OR MERCHANTABILITY AND/OR ANY IMPLIED WARRANTY OF FITNESS FOR A PARTICULAR PURPOSE.

Taylor Pittsburgh shall not be liable for any incidental or consequential losses, damages or expenses, arising directly or indirectly from the product, whether such claim is based upon breach of contract, breach of warranty, negligence, strict liability in tort or any other legal theory. Without limiting the generality of foregoing, Taylor Pittsburgh specifically disclaims any damages relating to lost profits, business revenues or good will, loss of crops, loss of delay in harvesting; any expense or loss incurred for labor, supplies, substitute machinery or rental; or any other type of damage to property or economic loss.

Any and ALL repairs must be pre-approved by Taylor Pittsburgh prior to any repairs being made and subject to all conditions, restrictions, and purchaser obligations as stated within this Warranty.

(continued on next page)

(continued from previous page)

Five (5) Year Limited Gearbox Warranty is a variable warranty based on purchase date, within one year from original purchase date, to the original owner. Warranty would include parts and labor based on all restrictions and limits stated above. Taylor Pittsburgh reserves the right to limit labor in hours and hourly charges. All repairs must be pre-approved prior to work being done. Years 2 thru 5 are parts only warranty. NO LABOR WILL BE PAID. Taylor Pittsburgh reserves the right to ask and inspect all parts prior to a warranty decision being made. Incidental expenses such as lubricants and transportation to and from the dealer are not covered by warranty.

It is the original purchaser's burden and obligation to maintain proof of purchase, a copy of which must accompany any and all warranty claims.

No agent, representative, dealer, distributor, serviceperson, salesperson, or employee of any company, including without limitation, Taylor Pittsburgh, its authorized dealers, distributors, and service centers, is authorized to alter, modify or enlarge this Warranty.

This Warranty is effective on any Taylor Pittsburgh product purchased January 1, 2008 and after and is subject to change without notice.

Answers to any questions regarding warranty service may be obtained by contacting:

Taylor Pittsburgh Mfg.  
305 Commerce Drive  
Winfield, AL 35594

1-800-228-2308(tel)  
1-205-487-0227 (fax)

Taylor Pittsburgh Manufacturing Inc., Winfield, AL, is a manufacturer of quality agricultural and rural lifestyle equipment, and is a division of King Kutter Inc. Taylor Pittsburgh Manufacturing Inc. offers a full line of three-point mounted and pull type implements including rotary cutter, rotary tillers, estate groomers, landscape equipment, and specialty equipment. For more information please contact Taylor Pittsburgh Manufacturing Inc.